

* MINIMUM NUMBER OF STRINGERS IS THREE
 ** INSIDE FACE TO INSIDE FACE OF RAILING SYSTEM

GENERAL NOTES:

SPECIFICATIONS: MATERIALS AND CONSTRUCTION OF THIS STRUCTURE SHALL BE IN ACCORDANCE WITH THE STANDARD SPECIFICATION FOR CONSTRUCTION OF ROADS AND BRIDGES ON FEDERAL HIGHWAY PROJECTS (FP-03) AND STANDARD SPECIFICATIONS FOR CONSTRUCTION OF TRAILS AND TRAIL BRIDGES ON FEDERAL PROJECTS,

TIMBER & LUMBER: SOLID SAWN TIMBER MEMBERS SHALL CONFORM TO THE REQUIREMENTS OF THE GRADING RULES AGENCY FOR THE SPECIES, TYPE, AND GRADE SPECIFIED BELOW.

DECK PLANKS, CURBS, SILLS, & BACKING PLANKS RUNNING PLANKS

- SOUTHERN PINE NO.2 GRADE GRADING RULES AGENCY - SPIB
- SOUTHERN PINE NO.2 GRADE GRADING RULES AGENCY - SPIB

RAILS & POSTS (SEE PROJECT CRITERIA)

UNTREATED

- BALDCYPRESS, S4S, NO.1 GRADE GRADING RULES AGENCY - SPIB
- WHITE OAK, S4S, SELECT STRUCTURAL GRADE GRADING RULES AGENCY - NELMA

TREATED

- SOUTHERN PINE, S4S, NO.1 GRADE GRADING RULES AGENCY - SPIB

TREATMENT: SEE PROJECT CRITERIA FOR MEMBERS IDENTIFIED TO BE TREATED AND FOR TREATMENT TYPE. PRESERVATIVE TREATMENT SHALL BE IN ACCORDANCE WITH THE CURRENT AMERICAN WOOD PROTECTION ASSOCIATION (AWPA) SPECIFICATIONS USING THE TREATMENT MATERIALS LISTED BELOW. TREATMENT WILL COMPLY WITH THE REQUIREMENTS OF THE CURRENT EDITION OF WESTERN WOOD PRESERVERS INSTITUTE (WWPI) "BEST MANAGEMENT PRACTICES FOR THE USE OF TREATED WOOD IN AQUATIC ENVIRONMENTS".

STRINGERS, DECKING, RUNNING PLANKS, & RAILING SYSTEM, IF TREATED

- AWPA USE CATEGORY SYSTEM (U1) FOR USE CATEGORY 3B ABOVE GROUND-EXPOSED (UC3B)
- PENTACHLOROPHENOL IN LIGHT OIL (TYPE C SOLVENT)
- COPPER NAPHTHENATE (CuN) IN LIGHT OIL (TYPE C SOLVENT)

SILLS, BACKING PLANKS, CRIBS, & TIMBER WALLS, IF TREATED

- AWPA USE CATEGORY SYSTEM (U1) FOR USE CATEGORY 4B GROUND CONTACT-HEAVY DUTY (UC4B)
- PENTACHLOROPHENOL IN HEAVY OIL (TYPE A SOLVENT)
- COPPER NAPHTHENATE (CuN) IN HEAVY OIL (TYPE A SOLVENT)

FIELD TREATMENT: COPPER NAPHTHENATE (2% SOLUTION) SHALL BE FURNISHED FOR FIELD TREATING OD WOOD. ALL ABRASIONS AND FIELD CUTS -APPROVED BY THE C.O.R.- SHALL BE CAREFULLY TRIMMED AND GIVEN THREE BRUSH COATS OF THE FIELD TREATMENT SOLUTION. WHERE APPROVED FIELD DRILLING OF BOLT OR NAIL HOLES IS REQUIRED, THE HOLES SHALL BE FILLED WITH PRESERVATIVE PRIOR TO INSERTING THE FASTENERS.

HARDWARE AND STRUCTURAL STEEL: SEE PROJECT DESIGN CRITERIA FOR STEEL HARDWARE FINISH. GALVANIZED OR UNFINISHED HARDWARE SHALL MEET THE REQUIREMENTS OF AASHTO M270, GRADE 36, WITH NUTS AND BOLTS CONFORMING TO ASTM A307, GRADE A. WEATHERING STEEL AND HARDWARE SHALL MEET THE REQUIREMENTS OF AASHTO M270, GRADE 50W, WITH BOLTS AND NUTS CONFORMING TO ASTM A325, TYPE 3. USE MALLEABLE IRON WASHERS AGAINST WOOD UNLESS OTHERWISE NOTED.

WHEN STRUCTURAL STEEL IS TO BE WELDED, THE WELDING PROCEDURE SHALL BE IN ACCORDANCE WITH AWS D1.1 AND SHALL BE SUITABLE FOR THE GRADE OF STEEL AND INTENDED USE OR SERVICE.

FABRICATION: SUBMIT SHOP DRAWINGS FOR ALL BRIDGE COMPONENTS (EXCEPT TIMBER RUNNING PLANKS). SHOW ALL DIMENSIONS AND FABRICATION DETAILS FOR ALL CUT OR BORED TIMBER. FIELD DRILLING OF HOLES SHALL NOT BE ALLOWED UNLESS OTHERWISE NOTED ON THE PLANS.

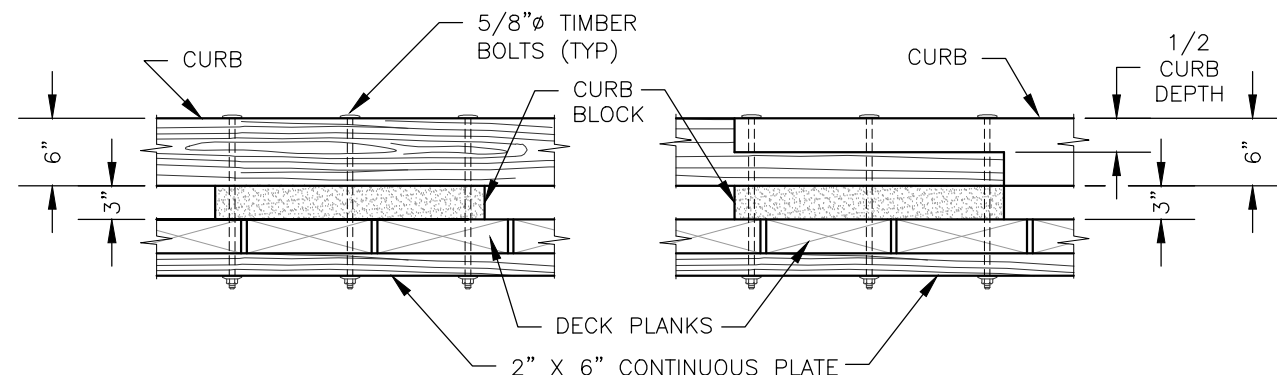
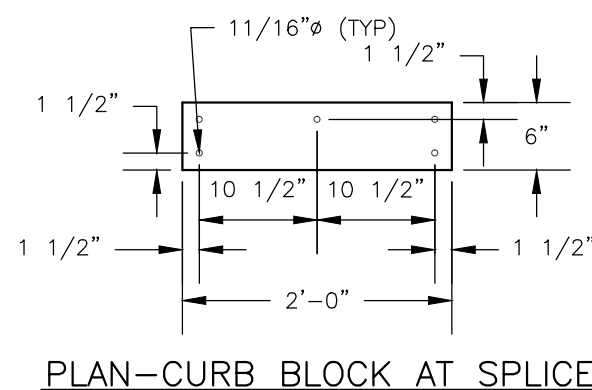
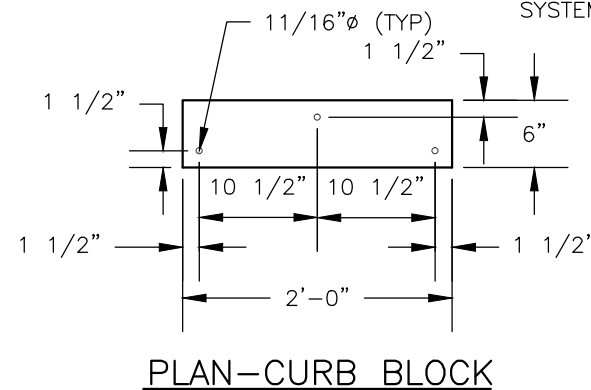

SOLID SAWN CURB CONNECTION DETAILS