



How To Operate And Maintain Septic Tank/Soil-Absorption Systems

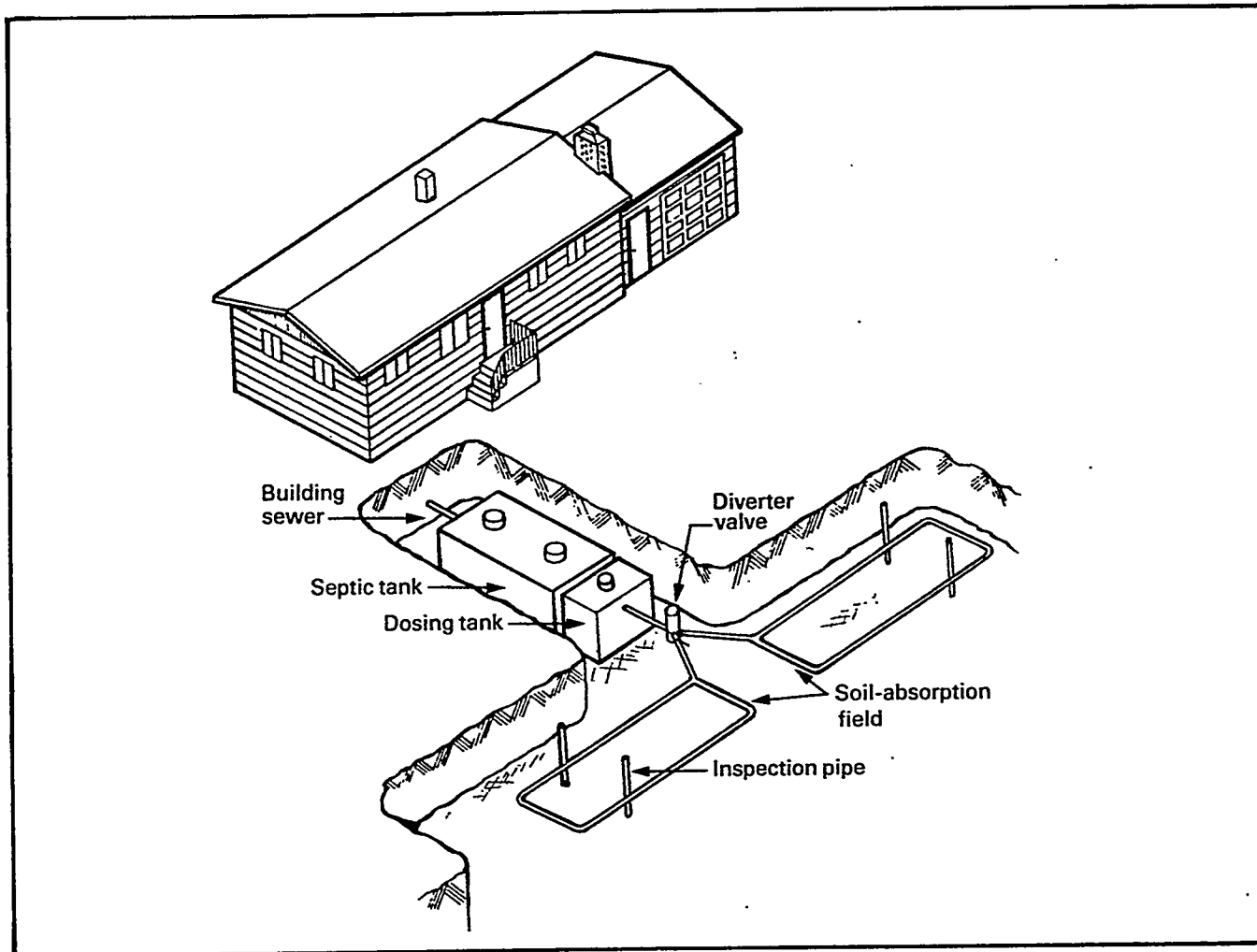

Figure 1. Typical ST/SAS.

A common method of treating and disposing of sewage (wastewater) at remote government-owned administrative sites and recreation facilities is the septic tank/soil-absorption system (ST/SAS). A properly operated and maintained ST/SAS (fig. 1) should last at least 20 years. A surprisingly large number don't. Studies reported at an Environmental Protection Agency seminar, Orlando, Fla., November 1979, show that over half fail prematurely due to improper operation or the lack of adequate maintenance.

Generally, these failures occur when the soil-absorption system becomes clogged. Preventable clogging, due to a buildup of solids in the system, is usually extensive enough to require expensive reconstruction of the system. Failures can also cause nearby ground areas, streams, lakes, and water supply systems to become contaminated. This exposes the public and field employees to health threats such as hepatitis, typhoid, diarrhea, and dysentery.

Two major components of a ST/SAS are the septic tank and the soil-absorption system, which can be a leach field, a leach bed, or a seepage pit. Sometimes a dosing tank is placed between the septic tank and the soil-absorption system to improve the flow of wastes into the system. And, sometimes the septic tank is served by two soil-absorption systems, rather than just one. Then, system use can be shifted

between the two, allowing one system to rest while the other is in use. This approach can add many years to the overall life of the ST/SAS.

SEPTIC TANKS

Typically septic tanks (fig. 2) are made of concrete, fiberglass, or a tough plastic. Wood tanks should not be used; they fall

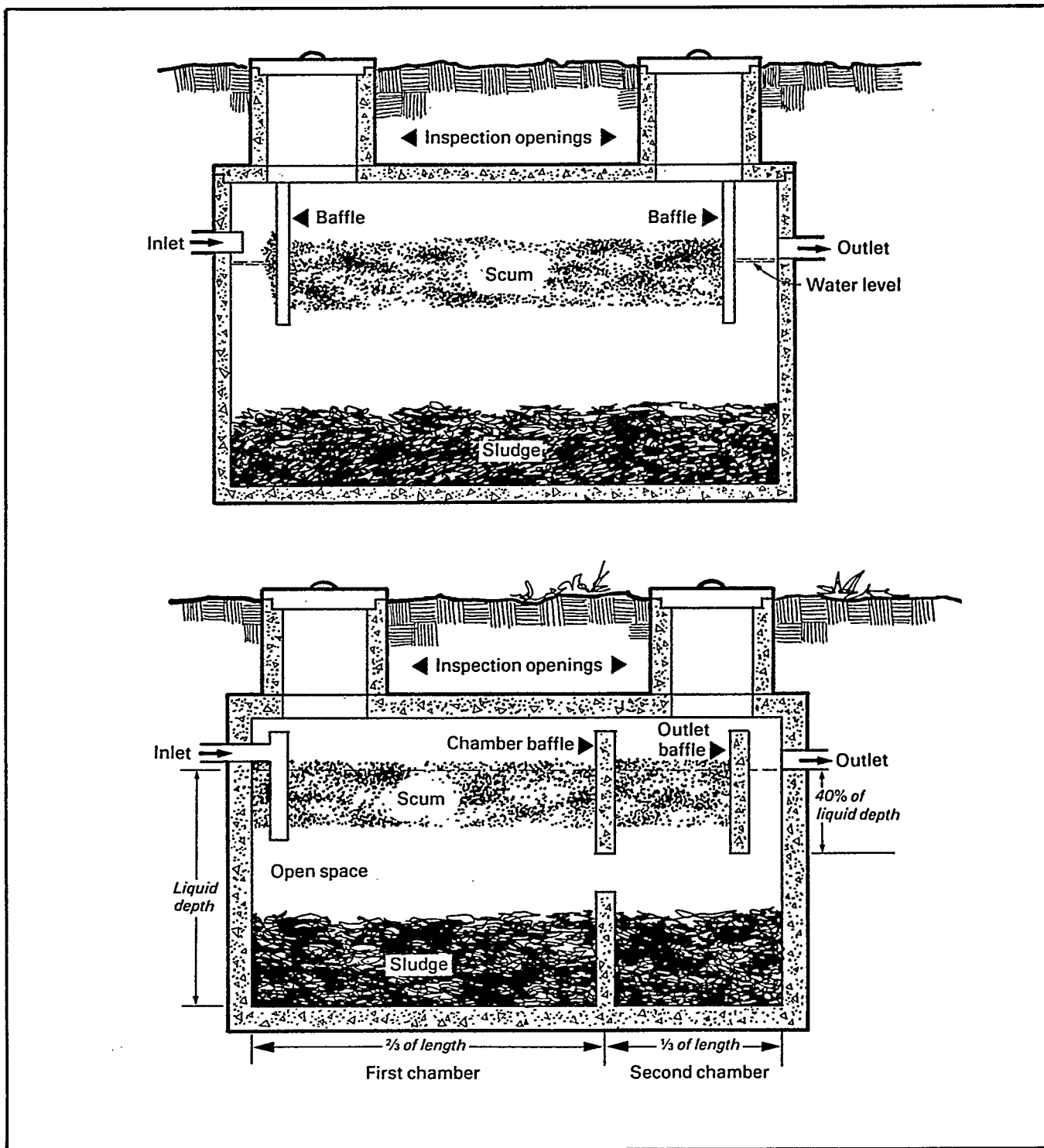

Figure 2. Typical septic tanks.

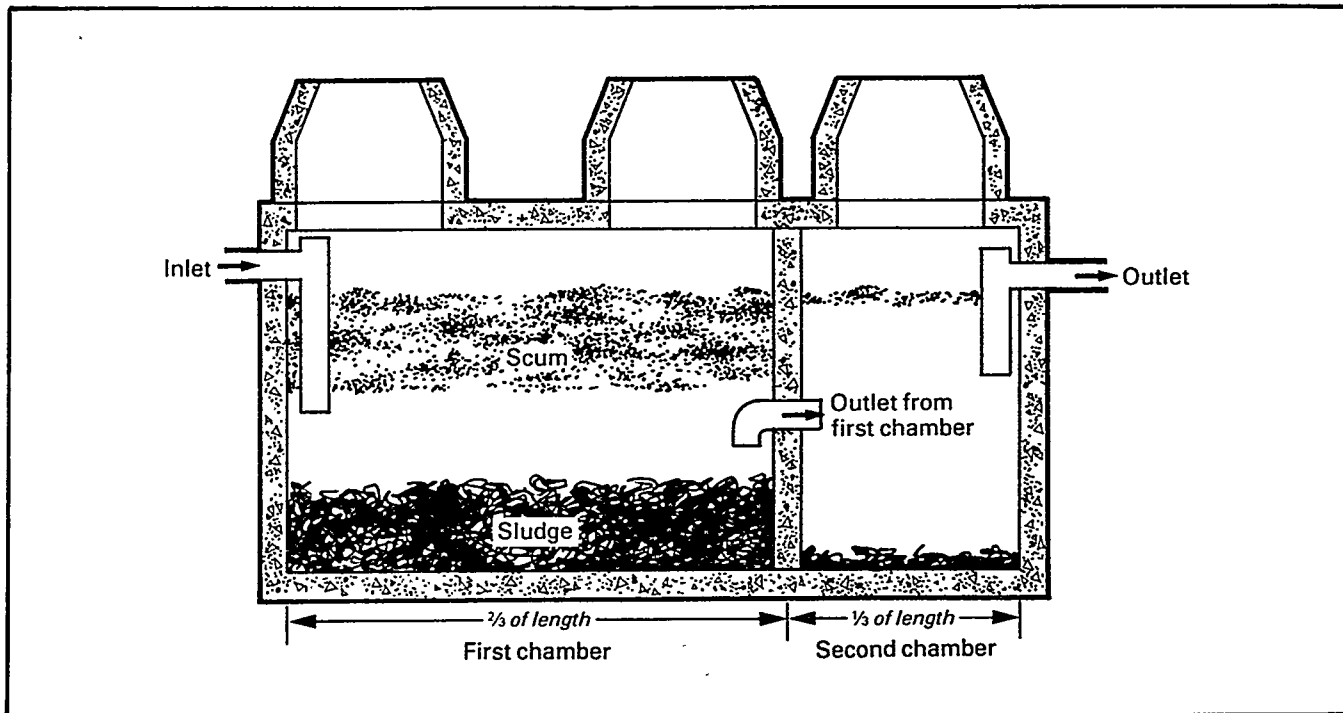

Figure 2. Typical septic tanks (continued).

apart much sooner than tanks constructed from the other materials. Also, steel tanks can rust through within only 5 years. The size of the tank to be used at a particular site depends on the amount of daily waste that is expected.

A septic tank is installed at a site by burying it below ground, usually with only covered inspection/pumping holes sticking out above the surface. These holes provide access to the interior of the tank for visual inspection and pumping out. Unless the tank is specifically designed to take traffic loads, be sure that it is not buried under a roadway used by cars or trucks.

The purpose of a septic tank is to keep solids that are in wastewater from getting to a soil-absorption system. Wastewater from toilets, urinals, sinks, etc. at the site of a ST/SAS contains solids that can clog the soil-absorption system. When too many solids get into the soil-absorption system, the system fails.

As wastewater enters the septic tank via the inlet (fig. 2), the water flows slowly through the open space in the tank, allowing solids to separate out from the wastewater. Heavy solids form a sludge layer at the bottom of the tank, while grease, oil, and other light waste material rises to the top to form a scum layer. As the two layers build up over time, the open space between them becomes smaller and smaller. The smaller the space, the greater the amount of solids that leave the tank via the outlet. That is why septic tanks should be pumped out long before the sludge and scum layers buildup to the point where they completely fill the tank and block the flow of wastewater.

As indicated in figure 2, septic tanks can have one or two chambers. Most of the newer tanks have two. The first chamber, at the inlet, is the longer of the two chambers and it traps most of the solids from the slowly flowing wastewater. The second chamber acts as a safety trap and catches most of the remaining solids before the water flows through the tank outlet.

SOIL-ABSORPTION SYSTEMS

The purpose of a soil-absorption system is to dispose of wastewater that has had most of its solids removed by a septic tank. This disposal consists of percolating the wastewater into the soil. That is, passing the wastewater through pipe perforations after it leaves the septic tank, and allowing it to trickle down through the ground.

The size of the soil-absorption system depends not only on the amount of wastewater, but also on the type of soil. Some soils absorb water more slowly than others; these clog up faster than others; here, the system should be larger. The unpreventable failure of a soil-absorption system eventually occurs when growth of the organic material in wastewater forms mats that are so large that they plug up the soil.

As previously stated, the three types of soil-absorption systems are the leach field, the leach bed, and the seepage pit. The field and the bed are similar in construction and operation. They are formed by placing perforated distribution pipes in a field or in a bed of gravel. The field (fig. 3) is a series of trenches that are up to 100-feet long and 1- to 3-feet wide. There is a perforated pipe in each trench.

On the other hand, the up-to-100-foot long bed (fig. 4) is either a trench wider than 3 feet, or is a large excavation limited in width only by the area available. The bed can have one or more distribution pipes. The depth of the trenches in

the field or of the bed, can range from 2 to 5 feet. Wastewater from a septic tank enters the leach field or the leach bed, exits through holes in the distribution pipe(s), and fills the air spaces in the gravel layer. From here, the wastewater

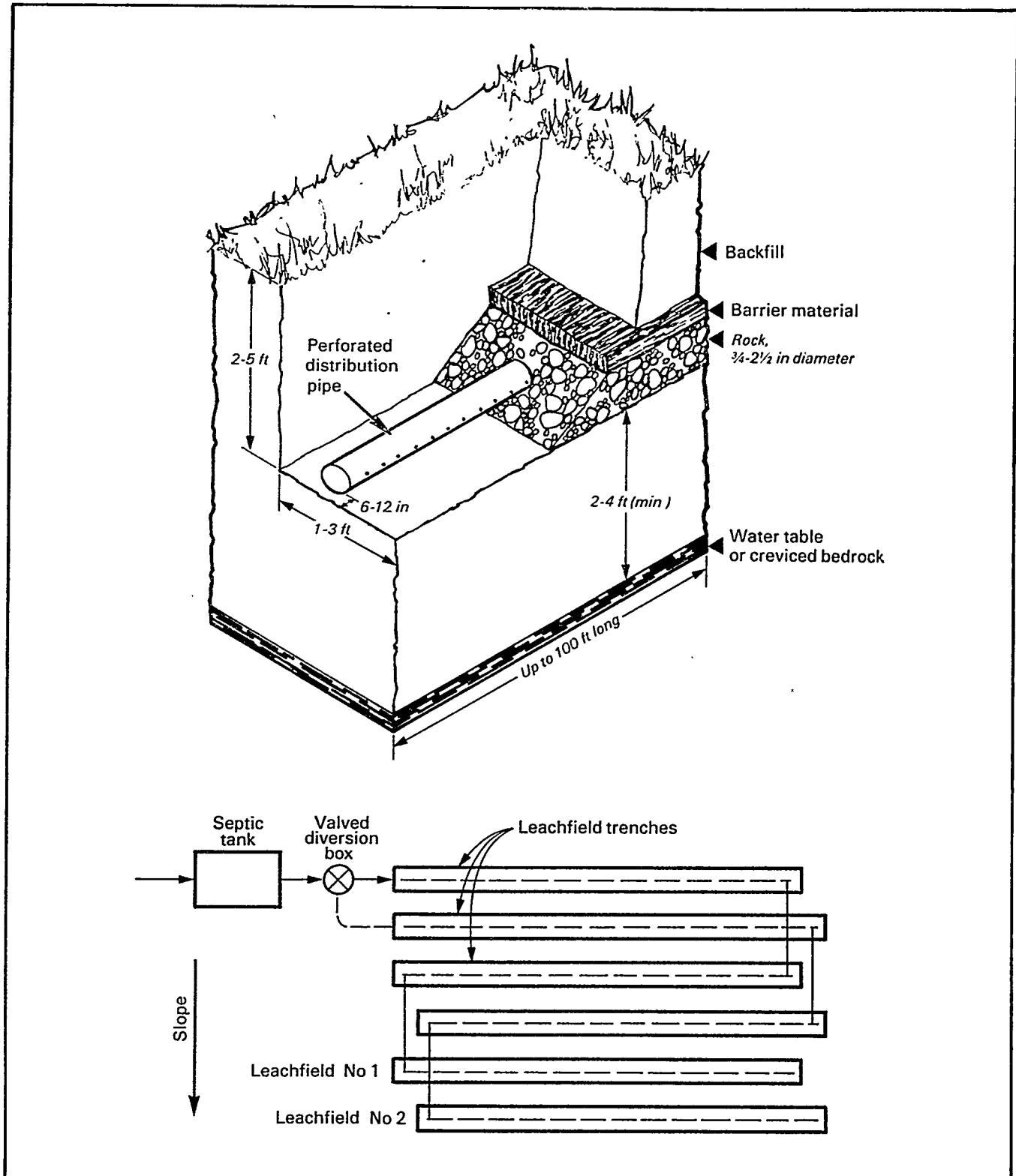

Figure 3. Typical leach field and trenches.

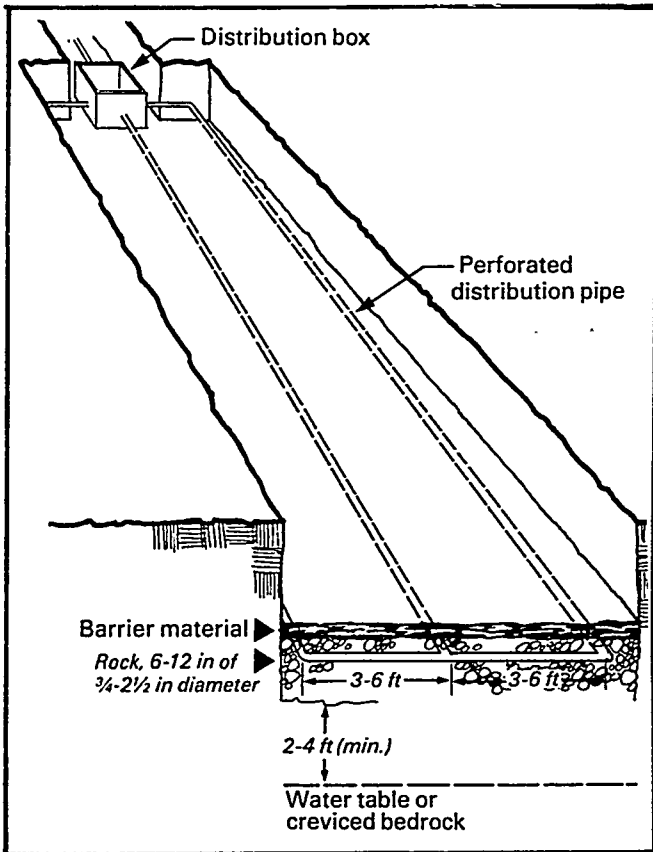

Figure 4. Typical leach bed.

percolates into the soil. Some soil-absorption systems have pipes that permit inspection of the percolation.

A seepage pit (fig. 5) is a hole in the ground that is lined with a permeable (leaky) material. The diameter and depth of the pit depends on how much surface area is needed to absorb the expected amount of wastewater, and also on the type and condition of the soil. A pit can be as small as 6 inches in diameter—just large enough to accommodate a perforated pipe as a liner. Some are as large as 10 feet in diameter and have un-mortared brick or (as is now more common) perforated concrete pipe placed inside as the liner. Wastewater flows from the septic tank outlet, fills the pit, and percolates into the soil through the pit liner.

DOSING TANKS

A dosing tank (fig. 6) is sometimes placed between a septic tank and a soil-absorption system to provide a controlled application (or dose) of wastewater to the soil-absorption system. The dosing tank stores small, intermittent discharges (such as toilet flushings), which pass through a septic tank, until the design optimum amount of wastewater accumulates. Then the accumulated wastewater is sent on to the soil-absorption system. Some solids that did not settle out in the septic tank will settle out in the dosing tank and, thus, not reach the soil-absorption system.

A dosing tank operates much like a toilet. It has one or two siphons that control the flow of wastewater out of the tank.

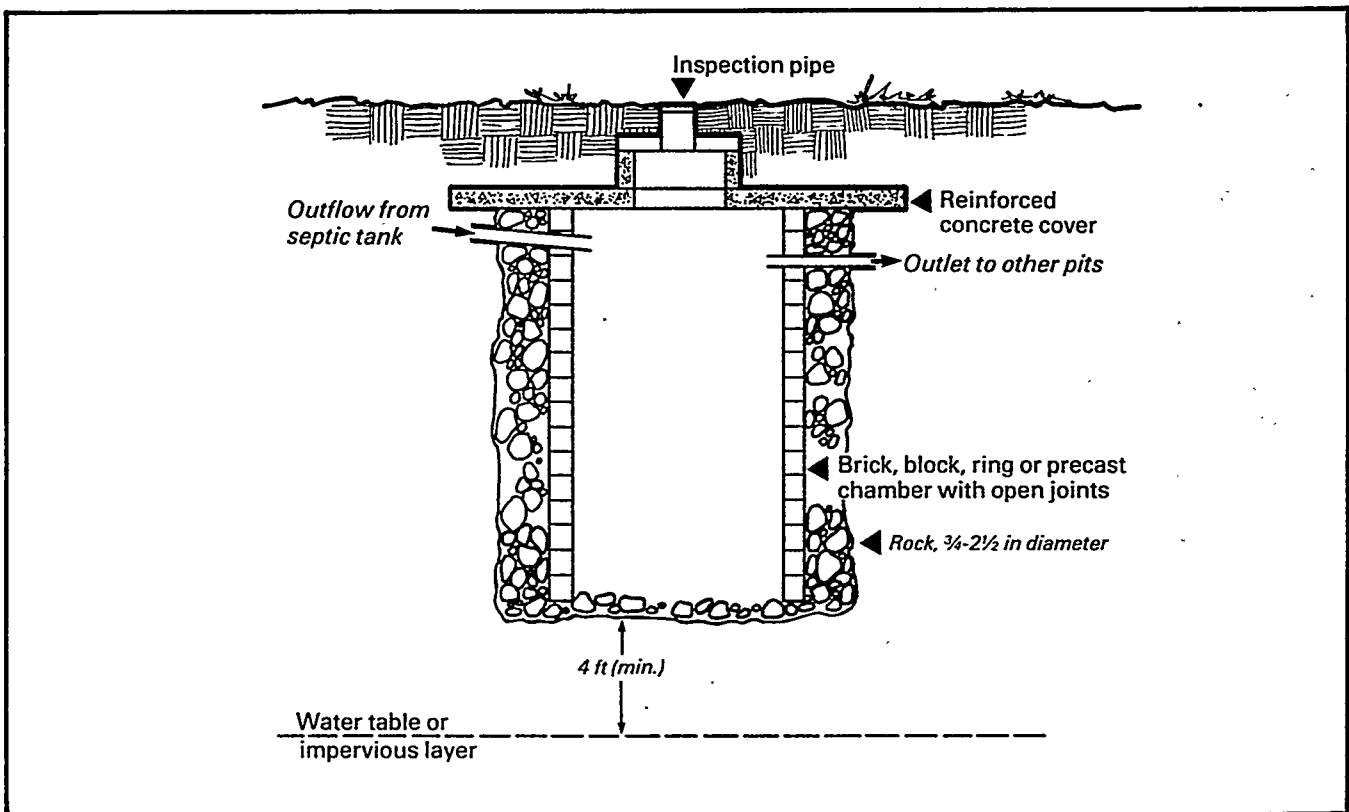

Figure 5. Typical seepage pit.

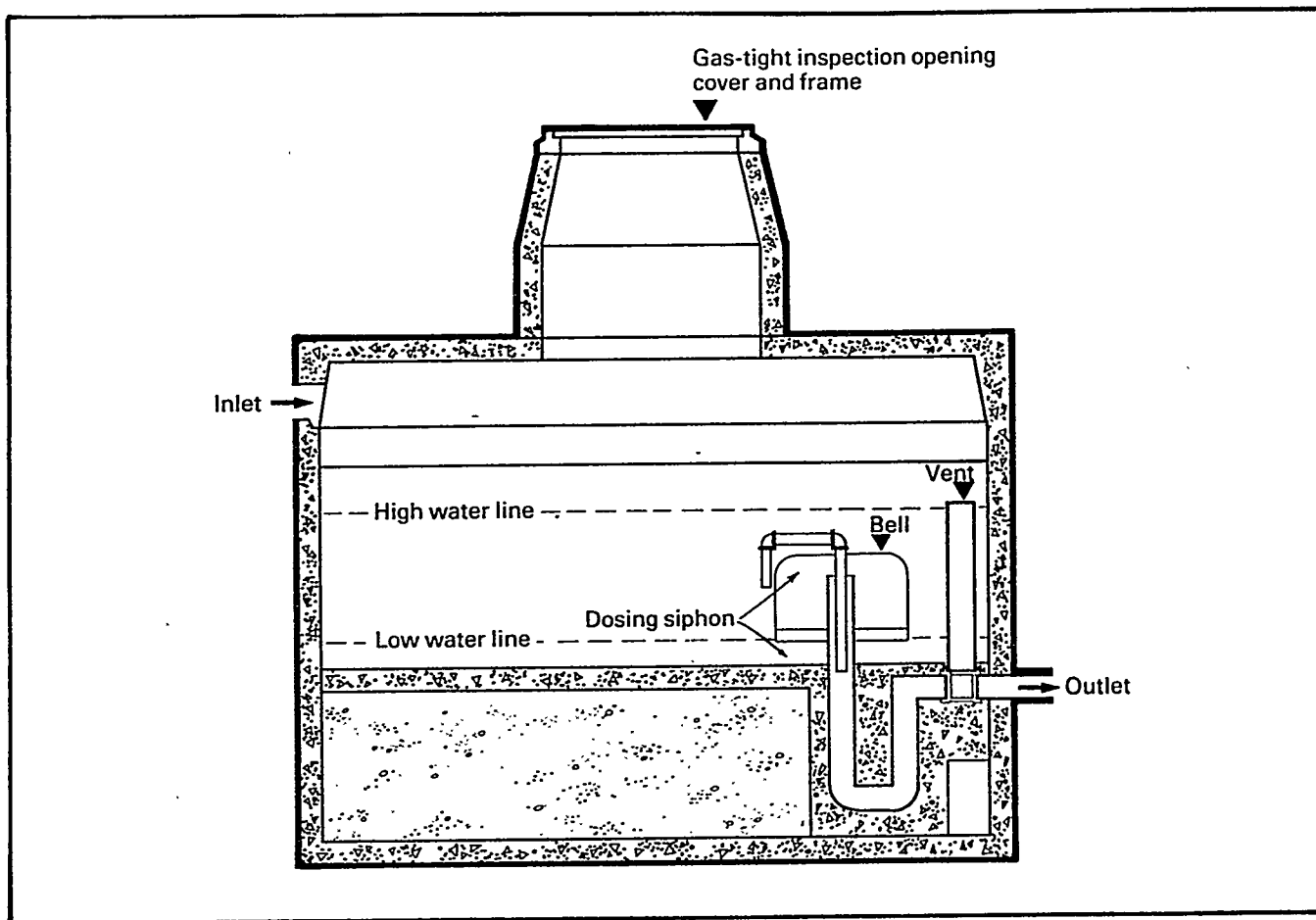

Figure 6. Typical dosing tank.

Tanks with two siphons alternate their use due to a difference in siphon water levels. When a siphon becomes full, it flushes a complete dose of wastewater into the soil-absorption system.

ST/SAS OPERATION AND MAINTENANCE

The main way to keep a ST/SAS from failing before it reaches its minimum design life of 20 years is to pump out the septic tank as soon as it should be pumped. Many chemical and biological additives for septic tanks are offered for sale to reduce pumping frequency. **DO NOT USE ANY ADDITIVE THAT HAS NOT BEEN APPROVED BY YOUR REGIONAL OR LOCAL SANITATION ENGINEER.**

Again, ST/SAS operation and maintenance consists primarily of the simple act of on-time septic tank **PUMPING**. The other operation and maintenance actions are on-time **MEASUREMENTS** of solid waste buildup in the septic tank, establishing and performing an **INSPECTION** routine for all elements of the ST/SAS, the keeping of complete **RECORDS** on the ST/SAS and its maintenance, and the reduction of waste creation at the site. Once a good ST/SAS operation and maintenance program starts at a site, plumbing items (such as toilets and sinks) most likely will require more attention than the ST/SAS.

Locating the ST/SAS

At some sites, the first step in starting an ST/SAS operation and maintenance program could be to find the ST/SAS. If uncertainty exists and specific knowledge as to the location is not available at the site, contact the designer or builder of the ST/SAS or the engineering department serving the facility for assistance. Obtain (or, if necessary, sketch) site plans and as-built drawings and, if possible, stake the ST/SAS location on the ground. Now you are ready to begin a program that should prevent the premature failure of the ST/SAS.

Pumping Septic (and Dosing) Tanks

Septic tanks have to be pumped periodically to remove the sludge and scum layers that buildup. Usually this should be done every 2 to 5 years, depending on how heavy the use is. The more solids that enter a septic tank, the more frequently it should be pumped. This means that if discharges from garbage disposals and dish and clothes washers enter the septic tank, it should be pumped out more frequently than a tank not receiving such discharges.

If a contract has not yet been granted to a pumping firm to maintain the site, look in the local telephone book Yellow Pages to determine which firms in the area offer this service.

Have your purchasing/contracts department sign up a reliable firm to accomplish the task.

A dosing tank also has solids that buildup on the floor of the tank. Generally, if a dosing tank is part of the system, it should be pumped when the septic tank is pumped.

Measuring Solid Waste Buildup

When to pump is determined by measuring solid waste

buildup. The sludge and scum layer buildups should be measured at least once a year, and more often if ST/SAS use is heavy. The measurements should be taken near the outlet for a single-chamber septic tank or the outlet of the first chamber in a two-chamber tank (fig. 7). If convenient, any contract with a local septic tank pumping firm can include measurements of the two solid waste layers as well as other maintenance tasks—all to be performed on a regularly scheduled basis.

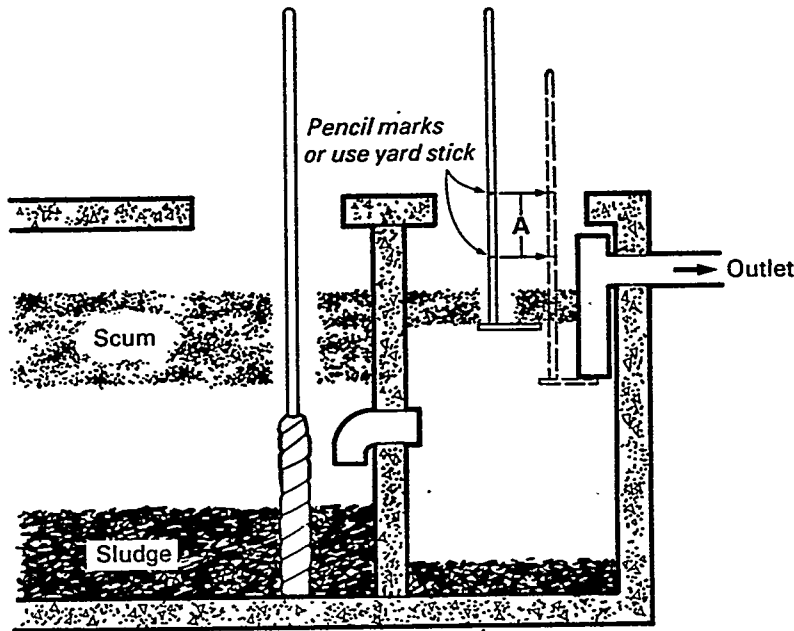
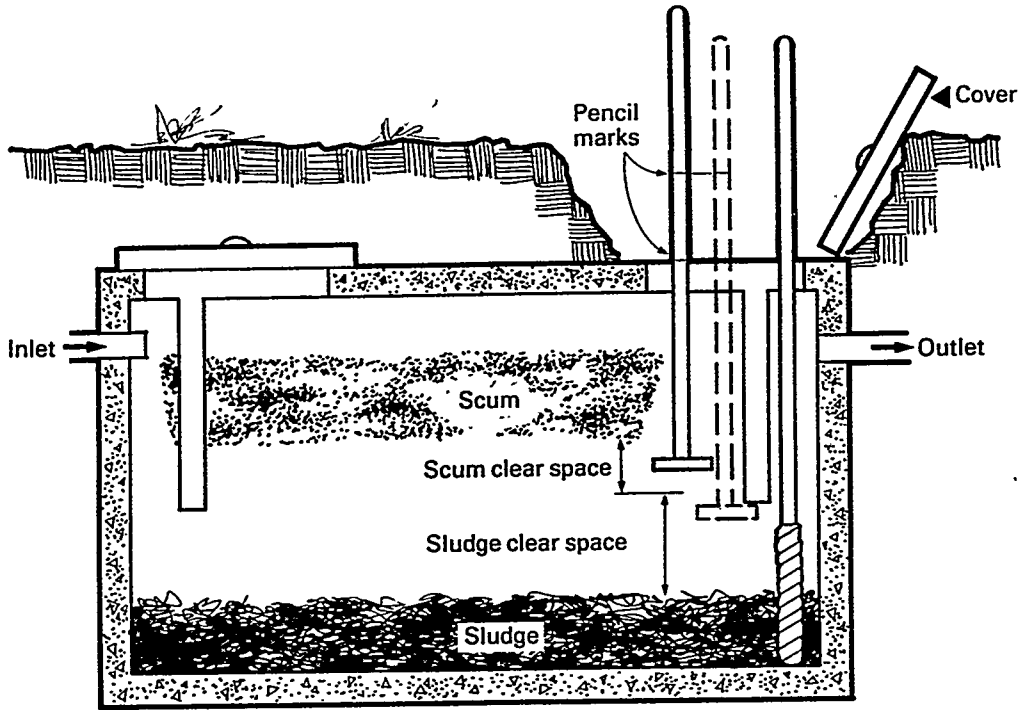

Figure 7. Measurement of scum and sludge layers.

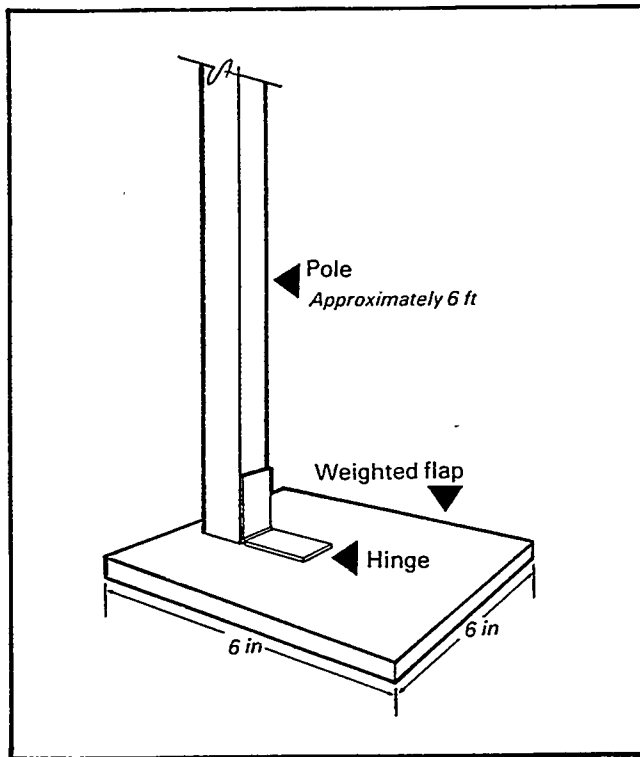

Figure 8. Simple scum layer measuring device.

First, measure the scum layer by gently forcing a stick, having a weighted horizontal flap attached by a hinge at the bottom (fig. 8), through the scum layer. As the stick passes through the scum, the flap is forced up against the side of the stick. When the bottom of the stick breaks through the bottom of the scum layer, the flap falls back to the horizontal position. Next, gently raise the stick back up until resistance is felt as the flap reaches the bottom of the scum layer. The point where the stick is just above the top of the scum layer now marks the depth of the layer. The distance can be determined quickly if a yard stick has been attached to the scum-measuring stick.

The depth of the sludge layer at the bottom of the tank should be measured next. This time, use a long pole that has rough, white toweling wrapped securely at the bottom (fig. 9). The towel-covered portion of the pole should equal approximately one-third the depth of the septic tank. Gently lower the pole (if feasible, through the hole in the scum layer left by the scum-measuring stick) to the bottom of the tank. Then, gently pull the toweled pole straight up and out of the tank. Measure the length of toweling that has sludge particles stuck to it—this gives the depth of the sludge layer.

Do not lower or raise the pole through an unbroken portion of the scum layer, since this would result in the scum layer scraping particles off the toweling. If a clear space does not exist in the scum layer, push a length of plastic pipe, having a hinged flap at the bottom, through the scum layer but not through the sludge layer. Insert the toweled pole through

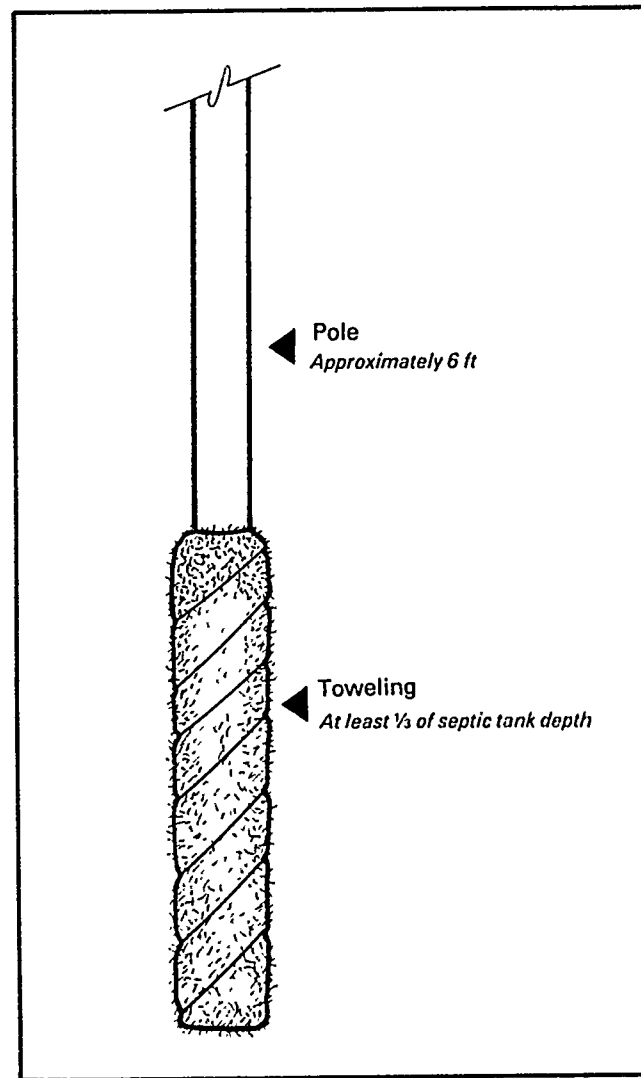

Figure 9. Simple sludge layer measuring device.

the pipe to take the measurement. Be sure that the diameter of the pipe is large enough so that the sludge toweling easily passes up and down the pipe without touching the wall of the pipe.

A device for measuring both the scum and sludge layer buildups can be assembled from a piece of extruded, clear plastic tubing (approximately 6-feet long with a 3/4-inch inside diameter), a rubber ball having a diameter of approximately 1 1/4 inches, and an attachment to the ball that is long enough so the ball can be held flush against one end of the plastic tube (fig. 10).

After wetting the interior of the plastic tube, gently wiggle the tube as you lower it through both layers of solid waste (fig. 11). Then, lift the tube just enough to pull the ball against the bottom of the tube. Next, press the device back down to the bottom of the tank to seat the ball firmly. Finally, gently lift the device straight out of the septic tank, rinse the outside of the tube, and then measure the two waste layers caught within the tube.

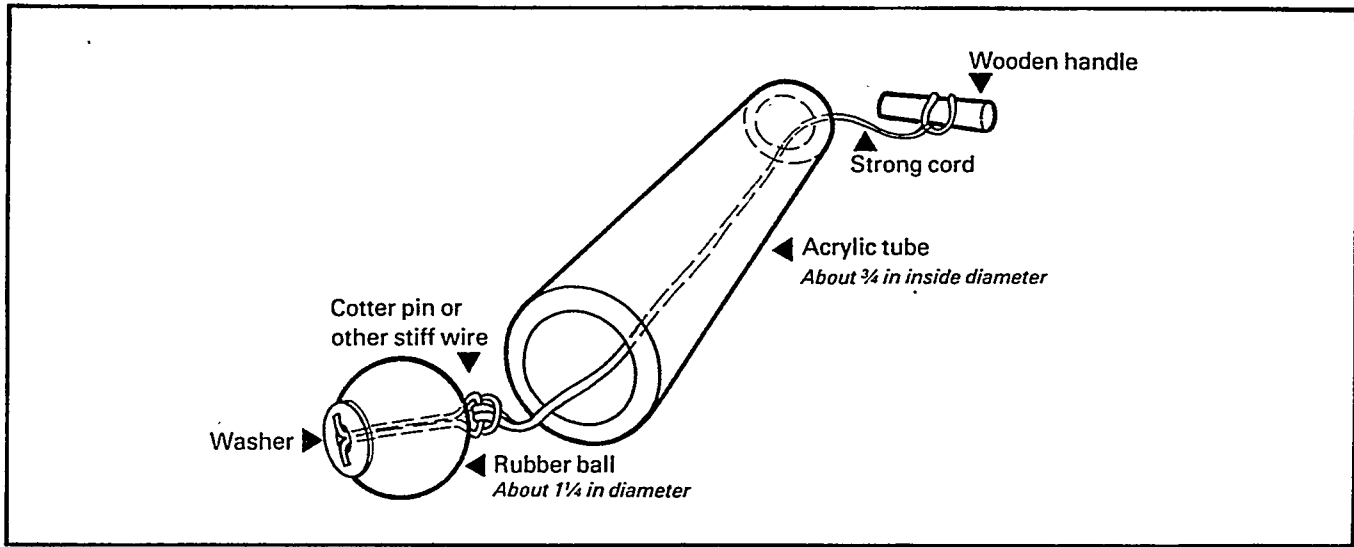

Figure 10. Scum/sludge layers measuring tube.

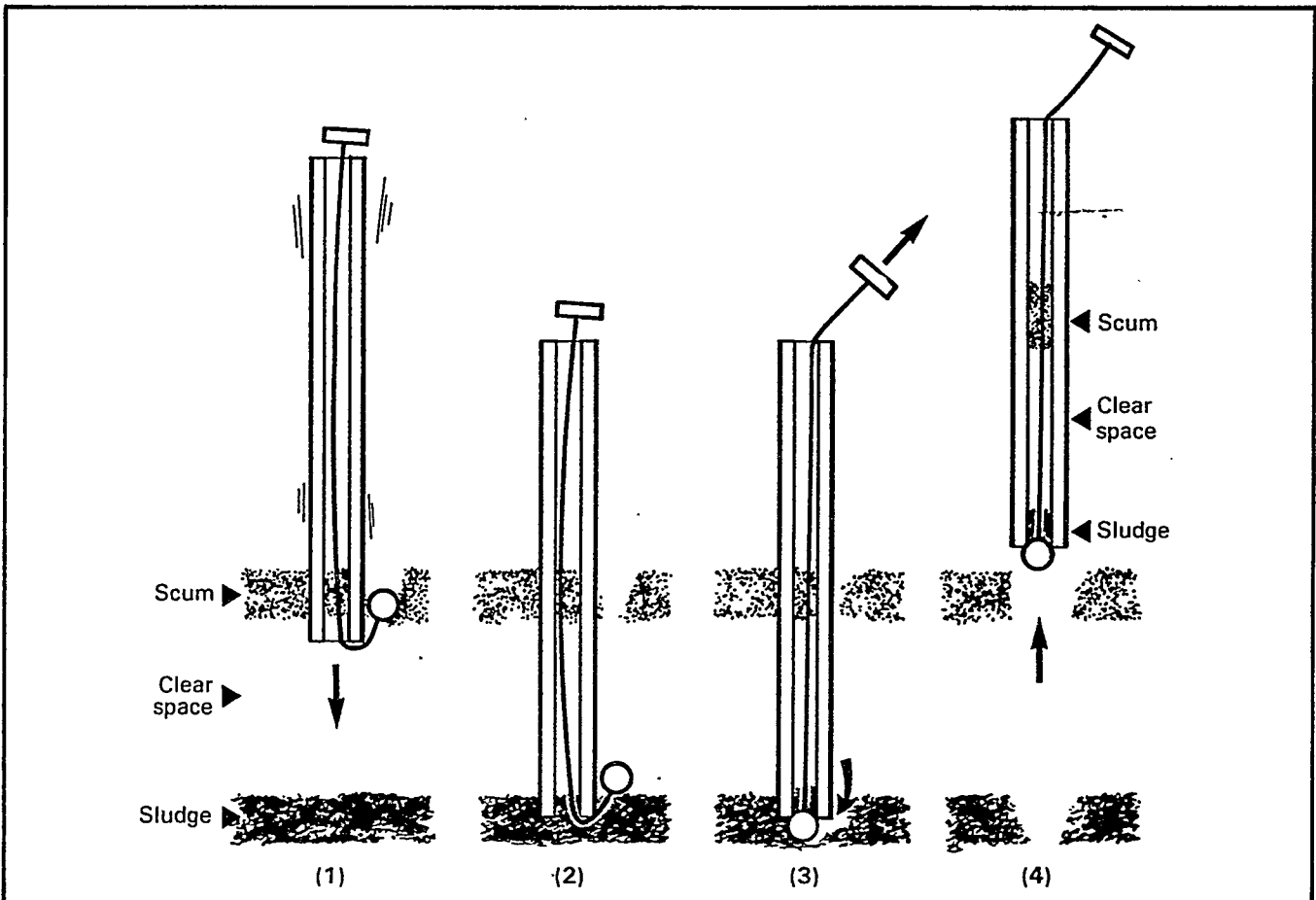

Figure 11. Use of measuring tube.

To keep the soil-absorption system from failing prematurely,
PUMP THE SEPTIC TANK WHEN:

- A. The **TOTAL DEPTH OF THE SCUM AND SLUDGE LAYERS** equals one-third the depth of the tank, **OR**
- B. The bottom of the septic tank outlet baffle (fig. 2) is less than 3 inches from the **BOTTOM OF THE SCUM LAYER, OR**
- C. The bottom of the outlet baffle is less than 6 inches from the **TOP OF THE SLUDGE LAYER.**

ST/SAS Inspections

Regularly scheduled visual inspections of the ST/SAS—performed at least four times a year, including during all septic tank pumpings—are important because they allow the user to detect discrepancies that could cause problems at a later date. These inspections should consist of observing all elements of the ST/SAS, including the dosing tank, if there is one. Look for cracks or other damage to the tank(s); make sure the siphon(s) work(s)—and alternate, if there are two—in the dosing tank. If inspection pipes are installed, observe the soil-absorption system to see if the wastewater is percolating properly.

Septic (and dosing) tanks can become cracked from settlement, ground movement, or the passage of vehicles over them. Early detection of cracks in a tank can prevent serious damage and expensive repairs at a later date. If a problem is suspected, or if wheel tracks are noticed over the tanks, an inspection should be conducted by *QUALIFIED PERSONS ONLY* at the next pumpout.

Perform the visual inspection by walking the entire ST/SAS from the administrative or recreation facility building, proceeding along the pipelines from the building to the tank(s) and on to the soil-absorption system(s). Look for potential problems: Observe if trees or brush are growing too near any element of the ST/SAS; whether there are wet spots—especially around the soil-absorption system (be sure to look downhill too); evidence of high ground water; or evidence of vehicular traffic over the ST/SAS.

Record Keeping

An Operation and Maintenance Record for each ST/SAS is a useful tool for highlighting and analyzing problems and for providing information to both supervision and new personnel. The Record should show dates of pump outs, all data from sludge and scum measurements, notes and observations from all inspections, and details on all repairs and alterations to the ST/SAS.

Reducing Wastewater Generation

By reducing the amount of sewage that a ST/SAS has to handle, potential problems can be avoided. This means starting a program at the facility to reduce the amount of wastes (liquid and solid) put into toilets, sinks, showers, etc. Watersaving devices for these can be purchased—the Forest Service San Dimas Equipment Development Center has information, available upon request, on many such devices.

The amount of solids going to a ST/SAS can be reduced by discarding thoroughly snuffed cigarette butts, used paper cups and towels, etc. into trash receptacles and by minimizing the amount of food wastes placed into garbage disposals (or eliminate garbage disposals at the facility altogether). Other substances that should not be disposed of through a facility's plumbing system include cleaning agents that contain disinfectants, insecticides, photography chemicals, degreasers, oils, and cosmetics or lotions that contain oils—these all add grease or oil to the scum layer or interfere with bacterial activity that occurs within septic tanks.

TROUBLESHOOTING THE ST/SAS

Toilets, sinks, tubs, and showers that won't drain or that backup are common plumbing problems that can occur within any facility. However, when facility sewage is disposed of through a ST/SAS instead of a sewer line, these plumbing problems can be an early indication that the ST/SAS needs quick attention. Delays in providing appropriate corrective action can result in costly failure of the soil-absorption system(s).

The troubleshooting chart presented here lists things that can go wrong with the ST/SAS, the possible cause, and how to attempt to correct the problem. Be sure that all problems, or even potential problems, are promptly reported to the maintenance or engineering department, facility manager, contract plumber, etc. Also, be sure to post all noted problems and their correction onto the Operation and Maintenance Record. Another good idea is to keep on hand tools and equipment needed for maintenance and repair of plumbing fixtures and pipes.

SAFETY

WORKING AROUND SEWAGE PRESENTS HEALTH THREATS. Be careful. Never enter a septic tank without proper safety equipment—including breathing apparatus and harness—and unless other people are present. Wear rubber gloves and boots when anywhere near either sewage or soil that has been contaminated with wastewater. Clean yourself and your gloves, boots, tools, and equipment thoroughly after each contact with sewage (wastewater). Never smoke, eat, or put your hands near your mouth when working with sewage. If ground-level soil has become contaminated, protect the health of facility users and employees by disinfecting the area with either chlorine powder or bleach.

Troubleshooting Chart

PROBLEM	POSSIBLE CAUSE	CORRECTIVE ACTION RECOMMENDED
A. Toilet, sink tub, or shower within facility not draining or is backing up.	Clogged trap. (This does not affect other fixtures.)	If traps are accessible, remove clog and dispose of in trash; use a plumber's helper or a snake when traps are inaccessible or clog is in toilet. Heavy use of drain-operating chemicals, liquid or crystal, is not recommended.
	Clogged pipes within building.	Check the outside cleanout to see if wastewater is standing in pipeline outside the building. If no wastewater is present, the clog is inside the building. Attempt to clear the clog with a snake; if unsuccessful, call a plumber.
	Broken pipeline outside the building. (This hardly ever happens.)	Call plumber. (Most breaks are discovered while trying to clear a clog. Breaks sometimes can be detected by noticing if soil is moist or puddles exist over or downhill from a pipeline.)
	Clogged pipeline between building and septic tank.	Usually indicates roots in the line; this requires reaming—contact plumber. (Frequent reaming of plastic pipelines can cause a break in the line—remove tree or root system near pipeline if line becomes clogged frequently.) To locate where to ream (or if tank pumping is required), check the level of wastewater in the septic tank. <i>A two-chamber tank:</i> Check in the outlet chamber; if the level is higher than the tank outlet pipe, the problem is downstream. If the level is at the outlet, <i>or a one-chamber tank:</i> Measure the scum and sludge layers (see main text). If these are overlimit, pump the tank <i>NOW</i> ; if not overlimit, check the tank inlet pipe for a clog. If the inlet is clear, ream the pipeline.
	Clogged pipeline between septic tank and soil-absorption system.	(If a dosing tank is present, see "B" below.) Check wastewater level in the soil-absorption system inspection pipes (if available). If no wastewater is seen, have the pipeline reamed. If wastewater is present, report a possible failure of the soil-absorption system and, if available, switch to alternate soil-absorption system. If no inspection pipes are present, have the pipeline reamed and, if this does not correct the problem, again: Report possible failure, etc.
B. Dosing tank will not drain.	Usually caused by pipeline clog; however, may be inoperative siphon.	Check the siphon vent pipe to see if wastewater is flowing into it. If not, see: Final possible cause in "A" above. If so, see "C" below.
C. Dosing siphon will not operate.	Most common: cracked or broken siphon bell or pipes; also possible: clogged pipeline.	See "B" above. If wastewater is flowing into the vent pipe, pump the dosing tank and inspect siphon—if the bell is broken, it can block the siphon. If the bell is OK, remove it and run a snake through the siphon to check for blockage. (If not blocked, see: Final possible cause in "A" above.) If block is found, report it immediately, since this indicates a serious problem. If wastewater flows out of the dosing tank, pump the tank and inspect pipes and bell for cracks or breaks. Repair or replace, if needed; if OK, report that cracks or breaks <i>may</i> be present in the dosing tank.

D. Dual dosing siphons will not alternate.	Cracked or broken bell or pipes; clogged pipeline.	Dual siphons <i>occasionally</i> may not alternate—this is <i>not</i> a problem. If observation shows that a particular siphon is not operating at all, see "C" above.
E. Wet soil or a puddle plus odor of sewage: 1. Along or near pipeline. 2. Around septic or dosing tank(s) 3. Over or near soil-absorption system.	Broken or cracked pipe. Broken or cracked pipe, cracked tank(s), or sewage backing up in tank(s). High groundwater levels, marginally failed system, or overloaded system.	Repair or replace pipe. Determine specific cause; repair or replace defective element(s). Report problem; management should determine if there has been too infrequent tank pumping, or if ST/SAS use has exceeded design capacity.

More detailed information pertaining to many of the topics presented in this *Equip Tips* can be found in the following document: Operation and maintenance manual for septic tank-drainfield sewer systems, Missoula, MT: Northern Region, Environmental Health Engineering, Forest Service, U.S. Department of Agriculture; August 1981, 38 p.

NOTE: The National Park Service, U.S. Department of Interior, was a cooperator in the preparation of this *Equip Tips* and provided advice and suggestions as to its contents.