

APPENDIX B

Snow Management Outside of Alaska

Snow Management Outside Juneau

Japan

Two methods of removing snow in Japan are the “slush removal system” and the “sprinkler snow melting system”. The slush removal system uses a method of dumping snow into water and mixing the two into a sherbet-like consistency before pumping it away through a system of pipes to a distant location. This system is largely used for clearing train tracks and allows snow to be cleared from the tracks by just six people, whereas before it would take up to 50 people using shovels. The sprinkler snow melting system, used mainly for roads, is a method of melting snow simply by sprinkling water on the roadway. It uses a pump that intakes water and supplies it to sprinklers where it is sprayed onto the roads via nozzles. The system used to primarily use groundwater but due to concerns regarding a lowering of groundwater levels and ground subsidence, the use of river water has recently been gaining prominence. Information on some of the Japanese snow melting systems is provided at the back of this appendix.

Sapporo, Japan is known for heating their roadways. Due to the high installation and operating costs, this has been justified only for areas of steep slopes. Another method used there is snow flowing gutters, or small conduits through which river water or treated sewerage is diverted and then mixed with snow. This system includes catch basin type areas where snow can be dumped into the curb are carried away by the water. These are used mostly by residents and small businesses to remove snow from sidewalks, walkways and bus stops. In other seasons the gutters are used to convey the storm runoff.

Finland

In the city of Helsinki, snow is hauled and dumped into snow disposal sites. Some sites dump directly into the sea. Another two sites use waste heat from wastewater treatments to melt the piled snow. Helsinki takes annual snow and water samples in the spring, and as of 1999, no environmentally harmful substances were found. To deal with trash collected with the snow, booms were installed at waterfront dump sites to keep the trash from floating into the sea.

Helsinki is considering new snow removal strategies. Last year, Helsinki received a record 200,000 loads of snow compared to 32,000 loads the previous year, overwhelming their snow storage areas. The City has considered setting aside areas in public squares and parks for piling snow in the winter but decided they are not suitable places for piling snow, as the large amount of melting snow could ruin the city’s lawns. With the large amount of snow Helsinki has received in the past, added with the shortage of dumping sites, the city worries that the largest piles of snow will not melt in time for the next winter. The City’s interim plan is to dispose of snow into the sea, although there are concerns about how it may affect ice levels in the city harbor.

Canada

Ottawa uses land disposal but is moving away from multiple smaller sites to fewer and larger engineered sites. The average snowfall in Ottawa is approximately 88 inches, generating 2.6 million cubic yards of snow that is to be removed from the downtown roadways. Of the city's nine permanent sites, three have been designed to include sound attenuation (berms and walls), visual screening and the collection of melt-water in a management and treatment facility.

The City of Montreal disposes approximately 9.2 million cubic yards of snow annually. The City operates about 25 snow disposal sites, most in the range of 1.5 to 6.2 acres. The city also uses the technique of "sewer chuting" in several areas. Snow is trucked to designed manholes where it is dumped into sanitary or combined sewers. These systems need to have a flow capacity to ensure that the snow is melted and that blockages do not occur. The system may be enhanced through mechanical means by pulverizing the snow as it is deposited. One system is able to process 20,000 cubic yards of snow per day through sewer chuting.

The city of Winnipeg uses land disposal only. The city operates nine snow disposal sites, five of which are used by contractors and the four others are used by city staff. All sites have been designed for snow disposal and most use retention ponds. Melt-water is discharged to storm drain systems or natural water courses. The use of snow melters was investigated, but deemed too expensive.

Toronto has used a variety of methods to dispose of snow over the years. In January 1999 the city experienced the worst snow storms on record with 45 inches of accumulation in back to back storms. Hardest hit was the downtown area due to a lack of on-street storage capacity, narrow streets and parallel parking on the majority of roadways. The city had activated 18 snow disposal sites, a sewer dumping location and five mobile snow melters.

Toronto has experience with two types of snow melter technologies. The Toronto mobile snow melting machine is designed to load and melt snow, discharging the water while the vehicle is in motion. The machine can be driven at 15 miles per hour, but most of the time it travels much slower in order to efficiently collect snow for melting. Toronto has found the method of melting snow to be very efficient and has been using it since 1974. The mobile snow melters are rated at 150 tons per hour. They also have two smaller portable melters rated at 80 tons per hour. Both systems use a water-filled tank that is melted using gas or oil-fired burners and melt the snow by



directing their exhaust gases into the water. They have found the main benefit to be that mobile snow melters eliminate the need for hauling snow.

Toronto also has one sewer disposal site. This required siting the sewer snow disposal facility at a location with enough flow to ensure the melting without plugging. There was consideration of adding additional sites but concerns were raised regarding the impact of adding these additional flows to the wastewater treatment facility.

Other U.S. Cities

Most cities in the Lower 48 states use land disposal for snow with freshwater or marine disposal allowed only in emergencies. There are a few cases where cities have stormwater discharge permits specifically for disposal to streams, lakes or the ocean. The Town of Camden in Maine has a permit to discharge into the Camden Harbor. Other communities use marine disposal during peak snow periods or snow emergencies, including the City of Baltimore (Chesapeake Bay) and the Town of Marblehead, Massachusetts (Salem Sound). Discharges into freshwater are much less common and in some cases the EPA has specifically prohibited this, such as in the Idaho Falls National Pollutant Discharge Elimination System (NPDES) stormwater permit.

Additional Information on Japanese Snow Melting Systems



Current Topics

YOKOTA[Top page
& Site map](#)[Contact us](#)

Snow Removal and Snow Melting

Excellent for pumping away slush and sprinkling water to melt snow ... YOKOTA's snow-fighting pumps (PAT.)



"The train came out of the long tunnel into the snow country..." So begins the famous novel, Snow Country, by Yasunari Kawabata. While the image of a "snow country" where so much snow falls that not a spot of ground is visible is certainly romantic, to those who live there nothing is as troublesome as the snow.

By the way, did you know that if we consider the complete surface area of Japan, half the country can be considered "snow country"?

While there are various protective measures against snow and ice that are taken to protect the lives and livelihoods of those living in "snow country", the greatest number of problems related to snow come from snowfall on railroad tracks and roadways.

One protective measure against snow and ice for railroads and roadways is the "slush removal system" that hydraulically transfers collected snow that has been removed from the railroad tracks or roadways and deposits it in a river. Also, there is the "sprinkler snow melting system" that melts snow by sprinkling water on the road surface.

A large number of pumps are used for these systems. While a normal pump might be sufficient in many cases, under severe conditions that require powerful suction force, such as hydraulically transferring slush with air mixed into it, an ordinary pump would not be able to perform the task. However, YOKOTA's Self-Priming Centrifugal and Enhanced Self-Priming Pumps can be used for pumping at locations with such severe conditions. Thanks to our unique continuous air-bleeding method (PAT.), difficult pumping situations can be handled with ease.

We will use some actual examples of railroad tracks and roadways to show how the YOKOTA Self-Priming Centrifugal and Enhanced Self-Priming Pumps are utilized.

Example application 1 - "Railway station snow removal system"



Railway station F in the Hokuriku region of Japan is located in a ravine, 8.5m below the bottom of a nearby river. Due to this, natural water drainage cannot occur. This is the main reason why the snow-flowing gutters (side-gutters where removed snow flows away) constructed early-on at a large number of stations could not be used here.

In the autumn of 1983, a new "slush-mixture pumping system" for snow removal was installed for the first time throughout Japan.

The system enables snow to be cleared from the tracks by just six people, thereby eliminating the tremendous delays and cancellations of trains due to heavy snowfall. To give an idea of what an advancement this represented, before the implementation of the new system, it would take 50 people using shovels one whole day to clear only the tracks around the switches.

What is the slush-mixture pumping system?

The "slush-mixture pumping system" was developed at the Snow Damage Testing and Research Center of the Niigata Prefecture Science and Technology Agency, and is a system that dumps snow into water, mixes the two into a sherbet-like consistency and then pumps it away through a system of pipes to deposit it at a distant location. It is also known as "hydropower snow transport".

Slush-mixture pumping system outline

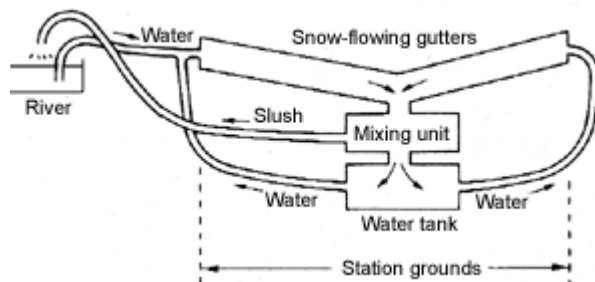

At this station, three separate snow-flowing gutters with a total length of 1.2km were newly installed along the tracks within the station.

Since only 5.2 tons of water per minute can be pumped from the river (due to river management conditions), a water storage tank was incorporated into the snow-flowing gutters and water previously suctioned from the river is held in this tank. By combining the 10 tons of water supplied from the water tank with 5.2 tons from the river, 15.2 tons per minute can be supplied to any one of the three snow-flowing gutters.

Snow on the tracks is suctioned up by a rotary snow removal train and deposited in the snow-flowing gutters. This snow is guided to the rotating screw in the slush mixing unit where it is finely ground.

It is then passed through a grated filter and the sherbet-like slush is pumped away through steel piping along the tracks to a discharge outlet located on a river approximately 900m away. 5.2 tons of water and 1.05 tons of snow come gushing out of the discharge outlet every minute. The remaining water that passes through the filter is circulated back into the water storage tank.

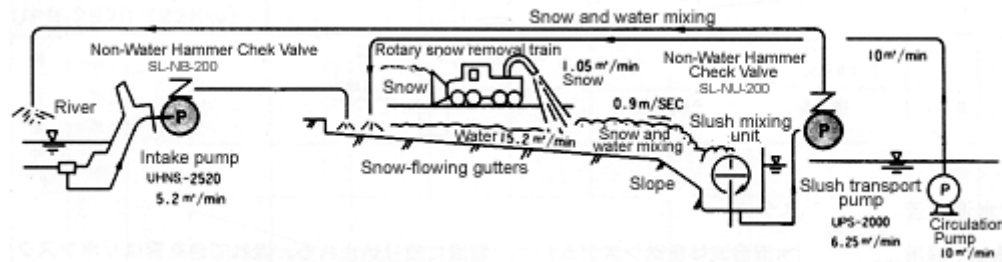

Why use YOKOTA pumps?

The two main pumping jobs for this snow removal system require an "intake pump" to suction water from the river and deliver it to the system, and a "slush transport pump" to pump the slush mixture (made from the river water and the removed snow) to the discharge point on the river.

A regular pump cannot possibly offer the capabilities, as listed below, required of these pumps.

- The "intake pump" must be capable of effectively suctioning and pumping water from the river through an extended suction piping system and, moreover, through piping that goes over embankments (elevated locations).
- Since the "slush transport pump" handles the slush ground by the mixing unit that contains 30% to 40% air, the pumping capacity of a regular pump attempting to suction this slush would be drastically reduced, resulting in pump stoppage. A pump that is capable of continuous slush suction operation while discharging contained air is required.

Therefore, YOKOTA Self-Priming Centrifugal and Enhanced Self-Priming Pumps have been selected since they possess the capabilities required to satisfy these strenuous requirements. Furthermore, YOKOTA's Non-Water Hammer Check Valve has been adopted for these pumps to prevent water hammer when the pump is stopped and ensure stable pumping.

Station grounds diagram

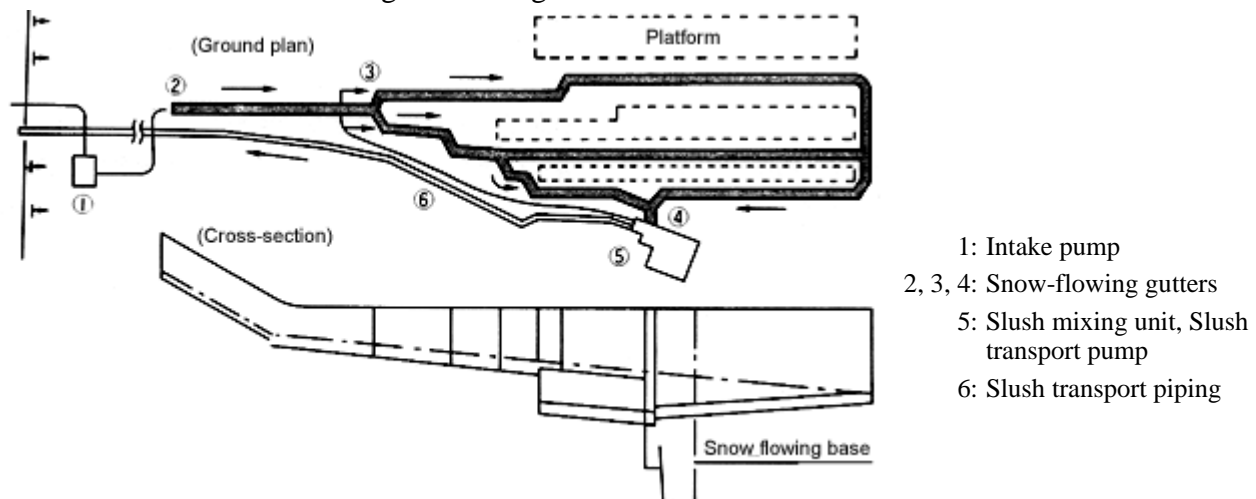

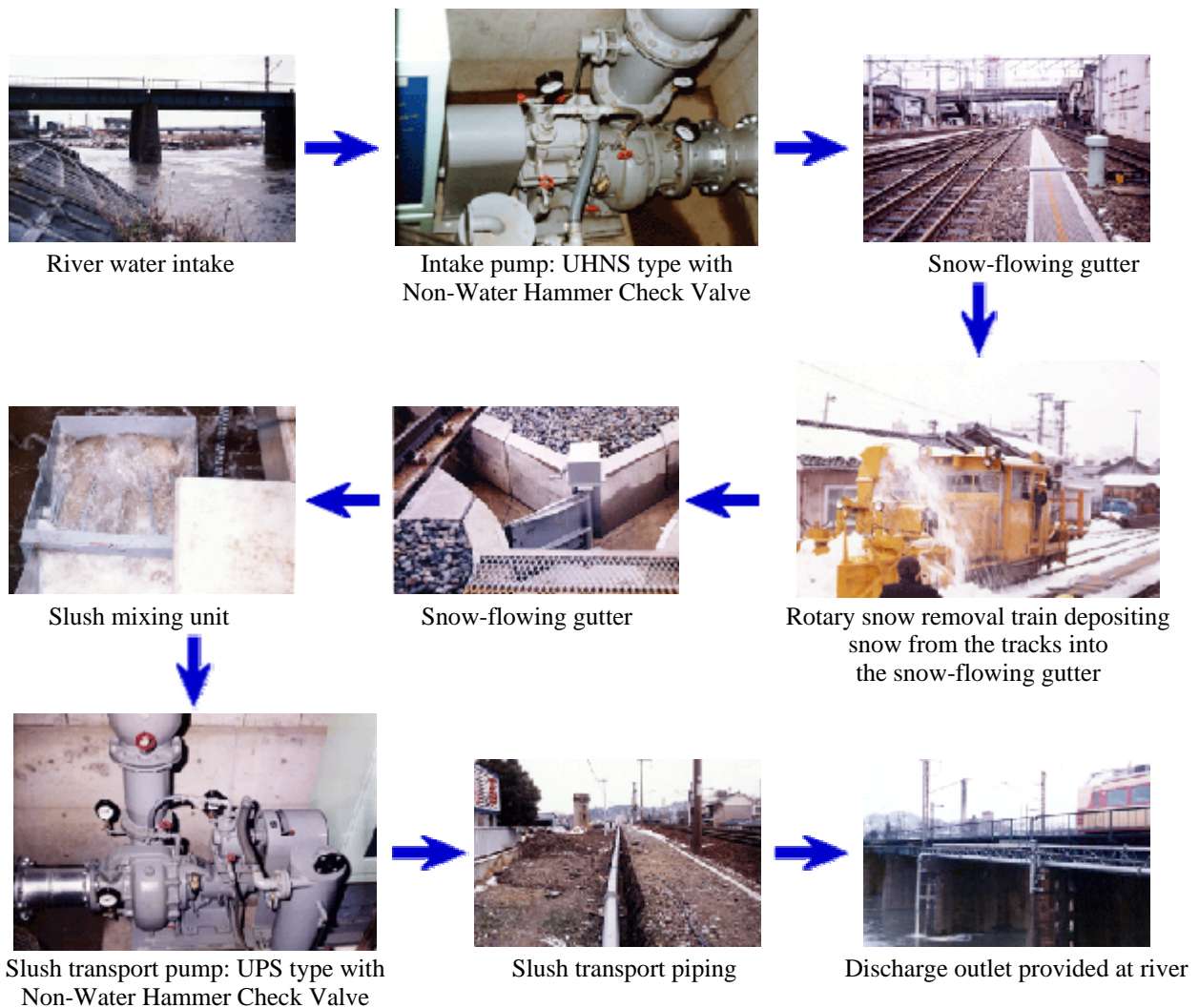

YOKOTA Self-Priming Centrifugal Pump UHNS type (PAT.) used for water intake ... Self-priming even with extended lengths of suction piping

The YOKOTA Self-Priming Centrifugal Pump UHNS type was chosen for the intake pump because it can handle the rigorous suction requirements of extended lengths of suction piping that goes up and over embankments.

The Self-Priming Centrifugal Pump with a strong self-priming capability is used as the main pump and is supplemented by a vacuum pump to further increase self-priming capability and reduce self-priming time. Also, a water-air separating impeller is installed between the main and vacuum pumps to provide our patented "continuous air-bleeding mechanism" that prevents water or mud from entering the vacuum pump.

Since the main pump possesses its own self-priming capability, the vacuum pump can be stopped under normal conditions.

Continuous air-bleeding mechanism (PAT.)

Self-priming mechanism (PAT.)

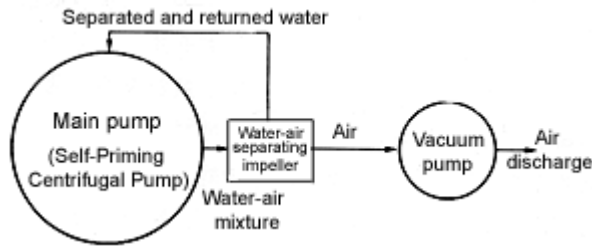

UHNS type structural view

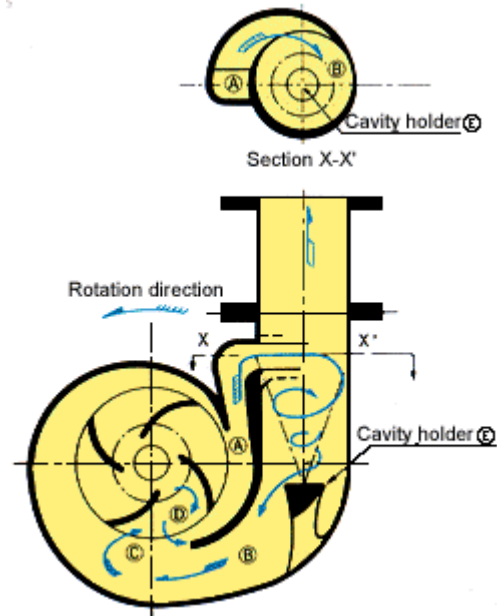
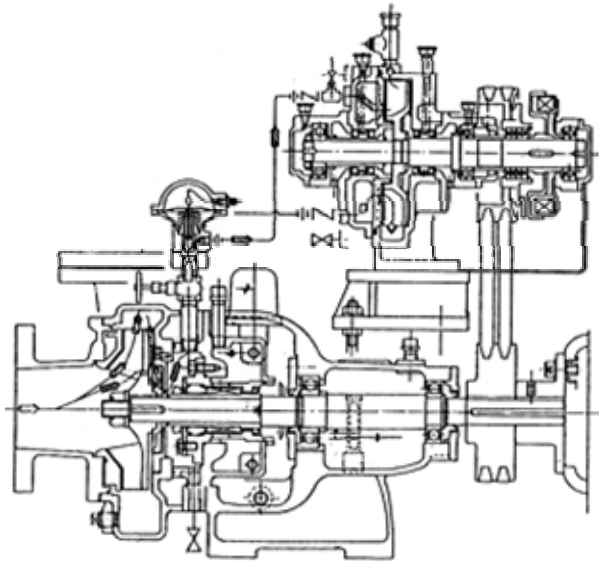

YOKOTA Enhanced Self-Priming Pump UPS type (PAT.) used for slush transport ... Discharges air while pumping

The YOKOTA Enhanced Self-Priming Pump UPS type with a non-clogging impeller was selected for the slush transport pump that is the central heart of this snow removal system.

The sherbet-like slush ground by the mixing unit contains 30% to 40% air, and is in a state of "multiphase flow", i.e., air-solid-liquid mixture.

A regular pump attempting to suction this slush would suffer a loss of pumping capacity or pump stoppage. However, the YOKOTA Enhanced Self-Priming Pump has a vacuum pump that operates constantly, removing air from the mixture to ensure constant and stable pumping. Also, slush cannot enter the vacuum pump due to the operation of the water-air separating impeller.

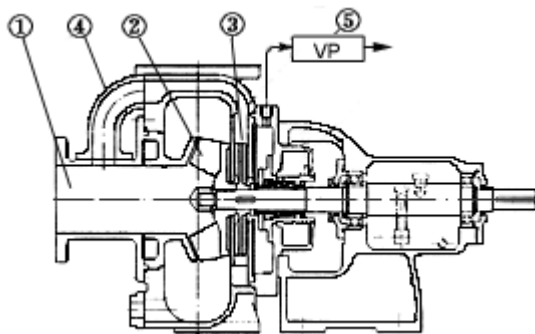

- 1: Suction inlet
- 2: Main impeller
- 3: Water-air separating impeller
- 4: Return passage
- 5: Vacuum pump

YOKOTA Enhanced Self-Priming Pump mechanism (PAT.)

1. The water-air separating impeller (3) is installed between the centrifugal pump and the vacuum pump.
2. When operation is started, the main impeller (2) of the centrifugal pump runs idle and the vacuum pump (5) operates, eliminating the air in the suction pipe.
3. When the air is completely eliminated, the pumping liquid flows into the pump casing, and is discharged by the main impeller (2).
4. The mixture of water and air in the center is drawn by the vacuum pump (5), goes to the water-air separating impeller (3) from behind the main impeller.
5. The water-air separating impeller (3) separates the water from the air instantly by centrifugal force.
6. The water returns to the suction inlet (1) through the return passage (4), and only the air collected in the center of the water-air separating impeller (3) is drawn out by the vacuum pump (5).

Accordingly, incoming air does not block the pump suction inlet or main impeller since the suction side is always operated under the vacuum pump's maximum vacuum and bleed amount conditions. This results in stable, high-level pump performance.

Moreover, because the movement of the water-air separating impeller prevents penetration of mud, sand, and earth in the vacuum pump, pumping efficiency is ensured and safe.

Example application 2 - "Roadway sprinkler snow melting system"

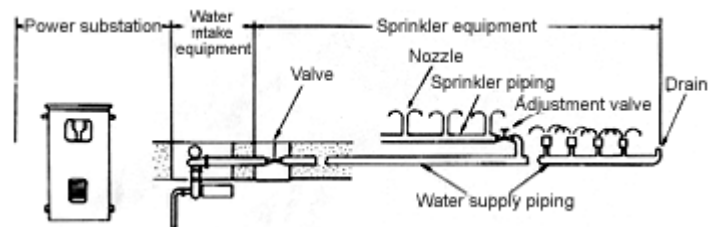

The "sprinkler snow melting system" is simply a method to melt snow by sprinkling water on the roadway. As shown in the figure above, it consists of a pump that intakes water and supplies it to the sprinklers where the water is sprinkled onto the road surface via the nozzles.

While various types of water, such as ground, river, sea, or hot springs water, can be used, conventional systems mainly used groundwater. But, since suctioning out too much groundwater can result in a lower water level or ground sinkage, the use of river water has recently been gaining prominence as a way to avoid these problems.

The main economic activities of Town K in Shiga Prefecture are agriculture and forestry-related. It snows 33 days out of the year and yearly snowfall is 290mm.

A sprinkler snow melting system was first introduced in this town in 1977. From that time until 1991, the system grew to consist of intake pumps in 15 locations and a snow melting pipe network with a total length of 9km. Of these 15 locations, the YOKOTA Totally Waterproof Self-Priming Centrifugal Pump System is installed in 3 locations for river water intake.

The main economic activity of Town K in Tottori Prefecture consists of pear trees, grape orchards, and other fruit farming. It snows 50 days out of the year and yearly snowfall is 900mm.

A sprinkler snow melting system was first introduced in this town in 1981. From that time until 1991, the system grew to consist of 11 sprinkling locations and a snow melting pipe network with a total length of 7.4km. The YOKOTA Totally Waterproof Self-Priming Centrifugal Pump System is also installed here in one of the locations for river water intake.

While these pumps intake river water, there are nearby river water irrigation channels for agricultural use that are not used during the winter from which water is drawn. However, since the water level is reduced in the winter, a cylindrical-shaped rubber balloon ("rubber dam") is used to block and store water, as shown in the figure, which can then be pumped out. Then, in spring, when the water is needed for agricultural purposes, the dam is deflated so that the water can be utilized accordingly.

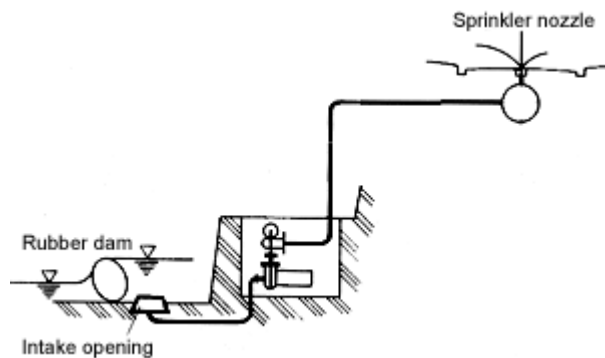

Why use YOKOTA pumps?

While submersible or horizontal centrifugal pumps are normally used for groundwater or river water intake, they have the following disadvantages:

Submersible pumps...

- The life of a submersible pump is reduced since it is constantly submerged in water and, at worst, may start to malfunction within one year and have to be replaced.
- Even if the pump only requires maintenance, a great deal of work is needed to pull it out of the water, increasing the overall cost.

Horizontal centrifugal pumps...

- While the life of a horizontal centrifugal pump is much longer than that of a submersible one, and maintenance of the pump is easier because it is land-based, it requires a site for the pump room.
- Countermeasures must be taken against noise and to prevent freezing in the winter.
- If air is suctioned into the pump, pumping capacity may be lost completely and, therefore, reliable automatic pump operation cannot be guaranteed.

However, all of these problems can be easily resolved by using the YOKOTA Totally Waterproof Self-Priming Centrifugal Pump System.

YOKOTA Totally Waterproof Self-Priming Centrifugal Pump System (PAT.) used for water

intake ... Self-priming system operates easily, even underwater

Advantages of the YOKOTA Totally Waterproof Self-Priming Centrifugal Pump System

- There is no need to worry about a pump site because the pump is located in an underground pit under a sidewalk or similar location.
- The pump has an advantage in that there is no need for countermeasures against winter freezing because the temperature in the underground pit is warmer than that at ground level. Another advantage is that noise is also not a problem due to the underground pump location.
- Although water may fill the underground pit, submerging the pump, there is no reason for concern because the pump with its attached submersible motor is completely waterproof.
- The greatest advantage of this pump is that it can continue pump operation easily even if air is suctioned into the system.

The Self-Priming Centrifugal Pump UHPR type with a submersible motor, with its strong self-priming capability, is used as the main pump, and is supplemented by the YOKOTA Vacuum Pump to further increase self-priming capability. Due to YOKOTA's unique continuous air-bleeding method (PAT.) the vacuum pump operates to bleed out air even if a large amount of air is suctioned into the system, so there is absolutely no need to worry about pump seizure due to racing of the motor.

- The YOKOTA Non-Water Hammer Check Valve (PAT.) is included to further increase operational reliability. Since the snow melting pipe is anywhere from a few hundred meters to over one kilometer in length, even one incident of water hammer is certain to spread system-wide and cause serious damage. However, the use of the Non-Water Hammer Check Valve provides reliable protection against the occurrence of water hammer.

In other words, the YOKOTA Totally Waterproof Self-Priming Centrifugal Pump System can be situated underground for hands-free operation due to it being submersible (completely waterproof) and capable of handling air mixed into pumped liquid (complete air-bleeding type). This pump system has been adopted based on its reputation for convenience.



Ground area above underground pit



Self-Priming Centrifugal Pump with submersible motor in underground pit

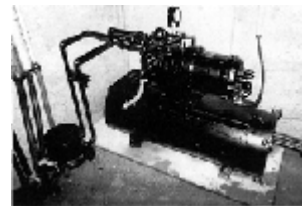

Vacuum pump in underground pit

- 1: Self-Priming Centrifugal Pump UHPR type (Main pump)
- 2: Vacuum pump
- 3: Non-Water Hammer Check Valve
- 4: No-Feed Detector

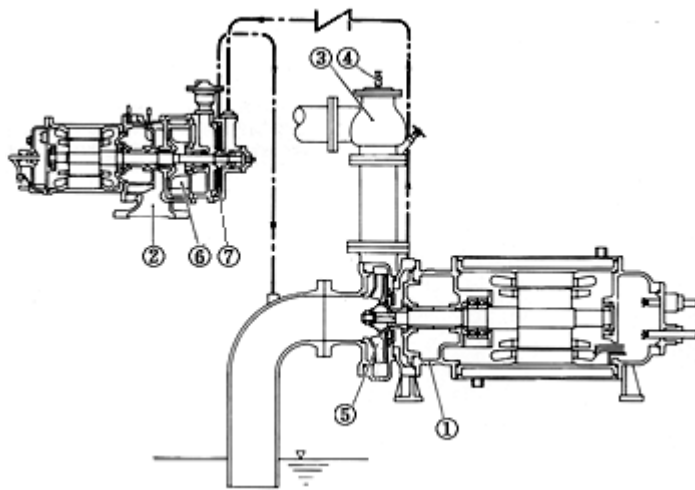

- 5: Main impeller
- 6: Vacuum pump impeller
- 7: Water-air separating impeller

With the addition of the Non-Water Hammer Check Valve and No-Feed Detector to the interlocked Self-Priming Centrifugal Pump UHPR type (main pump) and vacuum pump with submersible motors, the system offers completely automatic operation.

- (1) When the switch is turned on, the main and vacuum pumps are activated at the same time.
- (2) Air in the suction piping enters the main pump and then is rapidly discharged by the vacuum pump. When water fills the inside of the main pump, pumping begins.
- (3) When pumping begins, the vacuum pump automatically stops to conserve energy.
- (4) Pumping continues even if air is suctioned into the system due to the self-priming capability of the main pump.
- (5) If, by chance, a large amount of air is suctioned causing pumping capability to be lost, this will be detected by the No-Feed Detector, the vacuum pump will be activated, and air will be rapidly discharged due to simultaneous operation.

When the main and vacuum pumps are operated simultaneously, pumped water tends to flow toward the vacuum pump. With regular vacuum pumps, mud mixed in with the pumping liquid may cause a malfunction, but the air-bleeding system (PAT.) of the YOKOTA Vacuum Pump includes a water-air separating impeller (7), installed in front of the vacuum pump impeller (6), that separates water, mud, and other substances, returning them to the suction side so that only air is discharged to the outside.

The vacuum pump, protected by this structure, is able to rapidly discharge even large amounts of air so that the main pump is not stopped and continuous pumping operation is possible.

This allows completely hands-off operation capability and is a major advantage of the YOKOTA Vacuum Pump.

Regarding the YOKOTA Non-Water Hammer Check Valve (PAT.)

All of the above-mentioned pumps are equipped with YOKOTA Non-Water Hammer Check Valves for safe pumping.

- The Non-Water Hammer Check Valves close at exactly the moment when change in flow from the normal to the reverse direction occurs, that is, when the liquid in the pipes stops flowing after the pump is stopped. As a result, water hammer due to reversed flow does not occur, thereby preventing pipe ruptures and pump damage.

- The single-disk, simple construction eliminates breakdowns. Maintenance costs can be reduced considerably.
- The No-Feed Detector can also be installed optionally.

Pressure change with time after pump operation is stopped

YOKOTA Non-Water Hammer Check Valve

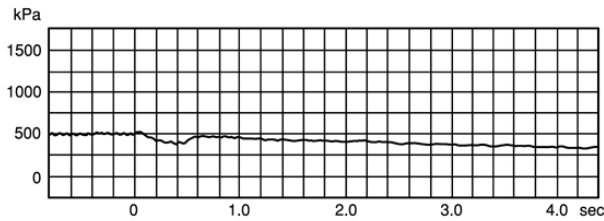

Conventional check valve

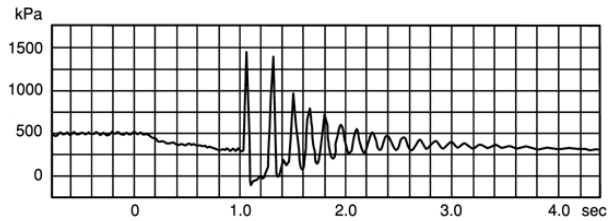

For details of each product, please refer to
[Self-Priming Centrifugal Pump UHN series \(UHNS, UHPR types\)](#)
[Enhanced Self-Priming Pump UPM, UPS types](#)
[Non-Water Hammer Check Valve SL series](#)

APPENDIX C

MOA Snow Melting Feasibility Report

Memorandum



THE BOUTET COMPANY

6927 Old Seward Highway, Ste. 201
Anchorage, Alaska 99518

Date: April 12, 2007

Tel: (907) 522-6776 ext. 207
Mobile: (907) 227-7475
Fax: (907) 522-6779
email: donna@theboutetcompany.com

To: Dan Southard
MOA Street Maintenance

From: Donna E. Gryder-Boutet, PE

Subject: Snow Dragon Snow Melter Demonstration

On Thursday, February 22, 2007, the Municipality of Anchorage (MOA) Street Maintenance Division of the Maintenance and Operations Department hosted a demonstration of the Snow Dragon SND900 snow melting unit, presented by Yukon Equipment and the Snow Dragon manufacturers. This memorandum summarizes the effort put into the demonstration, the results of the demonstration, and the costs associated with melting snow with the SND900.

PREPARATION AND PERMITTING

The demonstration project was originally proposed in November of 2006. Initial efforts were put into determining disposal options available for water generated by the snow melting unit.

Research revealed that the generated water would not be allowed to enter the MOA storm drain system, as melting the snow artificially creates a "point source discharge". As such, the water from the snow melter would have to meet State of Alaska water quality standards prior to discharge either into the MOA storm drain system, or any fresh water or marine water environment.

A study of stockpiled snow collected from downtown Anchorage streets was performed during the winter of 2005-2006 (June 2006, *Evaluation of Snow Disposal into near Shore Marine Environments*, CH2M Hill, prepared for Alaska Department of Environmental Conservation). The extensive data collection effort provided a general characterization of contaminants found in snow collected within urban downtown Anchorage. Extrapolating this data, it was determined that there was a reasonable likelihood that snow melt water generated during the trial would exceed State of Alaska water quality standards for at least one parameter.

Considering these restrictions, the only feasible alternative for such a short term discharge was disposal via the MOA sanitary sewer system. None of the data reported by CH2M Hill exceeded Anchorage Water and Wastewater Utility (AWWU) permit limits.

Once a specific timeframe and location were determined, an application for a Temporary Discharge Permit was submitted to AWWU; a permit was issued February 21, 2007.

SNOW MELTING DEMONSTRATION

The morning of February 22, 2007, the SND 900 snow melting unit was set up at the west end of East 20th Avenue, west of Cliffside Drive. Eight truck loads of snow, each load containing approximately 14 cubic yards, was pre-staged near the snow melter. Approximately 500 gallons of water was placed in the melting hopper; once the water was heated to the necessary temperature, operators began loading snow into the unit.

At 10:45 am, discharge into AWWU manhole SW31533065 began. Flow was routed through bales of straw and sorbent booms placed around the manhole to screen sediment and hydrocarbons from the effluent; a small percentage of the effluent did not enter the manhole, but flowed overland to the west. Operators made every effort to minimize the amount of overland flow to the extent possible.

Temperature of the discharge at the manhole entry point was measured 11:05 a.m. No evidence of either sediment or hydrocarbons was observed in the effluent at any time during the melting trial. A 5-gallon sample of the stockpiled snow, which appeared relatively clean and free of debris, was collected to determine approximate snow density.

Three additional loads of snow were hauled in between 11:15 pm and 11:23 pm. At 1:53 pm, after it had been determined that fuel for the SND 900 was running low, two loads of snow were removed from the demonstration site. The SND 900 continued to operate until 2:05 pm, at which time the burner was shut down. Photographs taken during the demonstration project attached.

DATA COLLECTED

The following summarizes the information collected during the snow melting trial:

- Snow density was calculated to be approximately 32.6lb/ft³, which is relatively dense.
- The total volume of water discharged was approximately 13,850 gallons. This estimate was based on the following data and assumptions:
 - 9 truckloads of snow melted
 - 14 cubic yards of snow per truck load
 - 32.6 lbs/ft³ snow density
 - The 500 gallons of water added to the SND 900 was balanced by the effluent that escaped overland;
- Temperature of the discharge entering the sanitary sewer system was 60.2°F.

SNOW MELTING COSTS

The following costs were associated with the snow melting trial:

Total Cost of Demonstration Project

Labor	\$2,208.00
Equipment (trucks, loader, water truck)	\$968.00
Mobilization/Demobilization	\$1,000.00
Total MOA Cost	\$4,176.00
Fuel (250 gal x \$2.80/gal) (1)	\$700.00
Total Cost	\$4,876.00

(1) Fuel provided by vendor; per gallon cost is estimate only.

These costs do not include time spent on up front planning or permitting.

The following table presents the cost breakdown per cubic yard of snow.

Cost Per Cubic Yard of Snow

Total Cost	\$4,876.00
Total Snow Volume Melted (9 loads x 14 cy/load)	126 cy
Cost per Cubic Yard (\$4,876.00/126cy)	\$38.70/cy
Cost per Cubic Yard including AWWU fee (approximately \$0.22/cy)(1)	\$38.92/cy

(1) AWWU waived the \$2.00/1,000 gallon disposal fee for this demonstration project.

SUMMARY

Approximately 126 cubic yards of snow was melted over a period of three hours and 20 minutes; the volume of snow melted was limited by the available fuel. The manufacturer's representative did state that he thought the SND 900 burners were not operating at full efficiency; a full load of fuel should have powered the unit longer, allowing for more snow to be melted.

AWWU disposal fees of approximately \$0.22 per cubic yard of snow would be a small fraction of the overall cost of melting snow. Fuel cost alone for this demonstration project was \$5.55 per cubic yard; labor and equipment constituted the largest percentage of the total cost.

To make snow melting a feasible tool for dealing with large volumes of snow in Anchorage, the cost of hauling and storing collected snow would have to approach \$40.00 per cubic yard – more if the cost of fuel continues to rise.

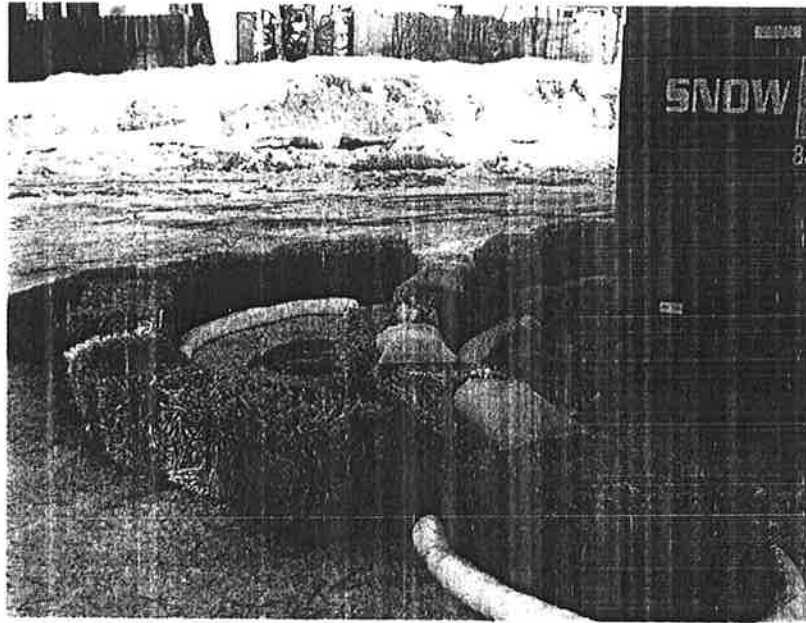

Photo1: Effluent control and screening prior to discharge.

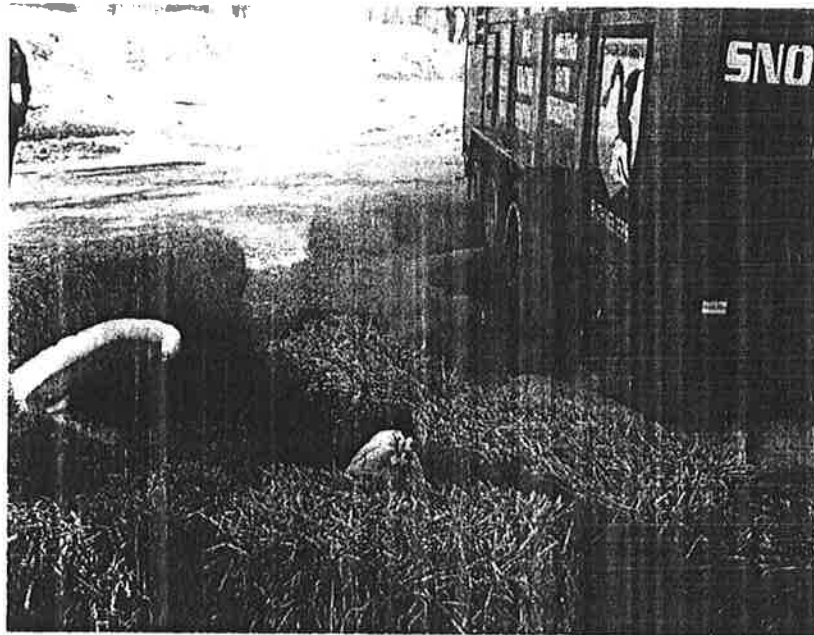

Photo 2: Snowmelter effluent discharge.



Photo 3: SND 900 in operation.



Snow Dragon

SND900 Spec Sheet

SPECIFICATIONS

Melt Rating	75 Cubic Yards per Hour (Based on 30lbs/cu ft snow density)
Fuel Type	No. 2 Fuel Oil or Diesel
Burner Output	9,000,000 BTU/hr
Fuel Usage	60 US Gallons per hour (max)
Fuel Capacity	250 US Gallons
Water Discharge Rate	120 Gallons per minute (max)
Water Tank Capacity	1,900 US Gallons
Weight Empty	Approx 12,700 lbs
Weight with Fuel & Water	Approx 29,000 lbs
Measurements	25'6" long x 8'5" wide x 6'10" high
Towing Speed	Empty 65 MPH / With Fuel 60 MPH / With Fuel & Water 50 MPH*

*Based on water level of 12"

STANDARD EQUIPMENT

1. Automatic ignition diesel fired 9,000,000 BTU/hr packaged burners.
2. Patent Pending engineered heat exchanger tubes.
3. Standard carbon steel inner dual weir system for debris separation.
4. Standard heavy gauge mild steel melting tank with structural steel supports.
5. Dual snow loading access on both sides of melter, each with 9'-10" of clearance.
6. Heated and lighted operating enclosures with lockable access door protecting equipment including burners, water pump spray system, and generator.
7. Lockable main control panel located on outside door panel for easy access.
8. Generator battery set up to be able to be plugged into a 110 outlet when not in use to power the generator block heater and optional battery charger.
9. Two (2) emergency shut down buttons located on both sides of the melter.
10. NEMA 4/12 main control panel with Honeywell temperature controller, visual and audible alarm indication, Honeywell high limit controller, pilot controls, indicators, gauges, relays and terminals.
11. Self contained diesel fired 20KW generator.
12. 200 gallons/min water recirculating stainless steel pump to mix and circulate water and to spray onto loaded snow.
13. Clean out hatch for easy cleaning.
14. Heavy duty tri-axle trailer with electric brakes, turn signals, marker lights and choice of ball hitch or pintal hook for towing arrangements.
15. Wood rail guards positioned on the melter to prevent damage to loading sides.
16. Quiet operation.
17. Equipment designed and built to comply with National Electric Code (NEC) and National Fire Protection Association.

OPTIONS AVAILABLE

1. Generator battery charger.
2. Stainless steel melting hopper and weir system.
3. Two (2) vibration resistance area/work floodlights.
4. Custom painting and/or decal of company logo.
5. Fifty (50) foot Fire Hose for fast and easy water start.
6. Service Contract
7. Articulating lift gate to allow a skid loader to be driven into the melting hopper.
8. As a custom engineered and manufacturing company, we can accommodate custom requests through our engineering department.

SNOW DRAGON™ SNOWMELTERS



SNOW DRAGON OVERVIEW

The Snow Dragon™ is the beginning of a revolution in the snow removal process. This "patent pending" commercial snow melting system will eliminate accumulated snow, even in the toughest conditions.

In 2004, Snow Management Group (the largest snow contracting firm in North America) teamed up with Park-Ohio Company (NASDAQ – PHOH), the world leader in oven and heat exchanger technology, to design an affordable, highly efficient and technologically advanced product for melting snow.

From this partnership evolved Snow Dragon™, LLC. With Park Ohio's financial might and John Allin's background in the snow industry, the Snow Dragon™ snow melting system is quickly becoming the standard in the industry.



Using the very latest advances in heat exchanger technology this product presents an economically viable solution to the very expensive and environmentally unfriendly process of physically hauling and relocating snow. Now in full production, Snow Dragon™ snow melters provide a cost effective alternative for snow contractors, facilities managers, municipalities and airport operations alike.



How do Snow Dragon™ Snowmelters Work?

Snow and ice are deposited into a hot water bath that is integrated with heat exchanger tubes. The burner fires into the tubes creating a burner boiler type system heating the water. A spray system is incorporated in the melting hopper where warm water is sprayed over the snow to promote further melting. As snow is dumped into the melting hopper and the water level rises, standpipes from within the unit further screen out particles while water drains out from under the unit. Several screens also filter out dirt and debris so that storm water relocation systems are not clogged or impeded. Thus water leaving the melter is cleaner than the snow being dumped in. Contaminants contained in the melter can then be hauled and dumped at a designated site, if required.

For security conscious users, eliminating a parade of trucks on and off a site allows for less outsider intrusions to protected areas. And, since these units are portable, piling snow can be done in a manner most convenient to the snow moving equipment operators instead of having to move the snow great distances to where the melter is located.

For more information on how Snow Dragon™ offers you a better tool for managing your snow removal process or to tour our 145,000 sq ft manufacturing facility located in Cleveland Ohio, call Snow Dragon Sales at 216.531.1599 or visit us online at www.SnowDragonMelters.com.

SNOW DRAGON™ SNOWMELTERS



SND900 MINI PRO MODEL

The Snow Dragon™, SND900 MiniPro Model is designed for use at strip malls, schools, parking lots and is the ideal configuration for landscapers and contractors.

This model is rated at economically melting 75 cubic yards of snow per hour, based on a snow density of 30lbs per cubic foot. This model is a commercially rugged unit fabricated on a tri-axle trailer, can be towed from site to site with a one-ton truck and can carry a skid loader along inside. Measuring twenty-five feet long and eight and a half feet wide, it is capable of fitting in tight places. The SND900 also measure less than seven feet high without the skid loader inside to be able to fit into low areas such as parking garages.

The SND900 has been engineered to be a low maintenance, easy to operate, and extremely mobile unit. The heated operating enclosure has two double doors on both sides for easy access. The heated enclosure protects the burner, fuel tanks, generator, water pump system as well as other major components from the weather elements. The control panel is also fabricated on the door so it can be accessed from the outside.

Easy access side loading, from both sides, is one feature with the MiniPro. The melting hopper tank measures a total of fifteen feet long with a ten-foot length area for dumping snow. Other features with this model include, one-man operation capabilities, plug and play components, quiet operation, built-in lighting system, and visual and audible alarm indication.

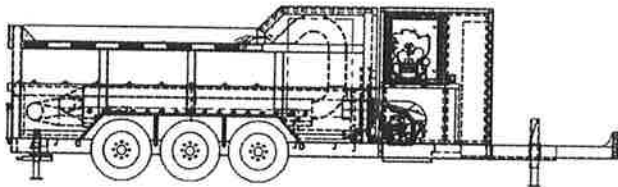
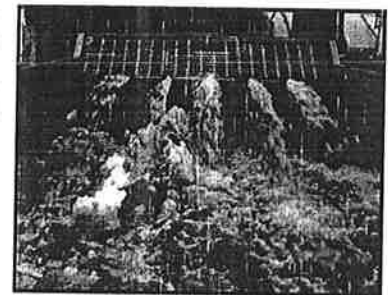
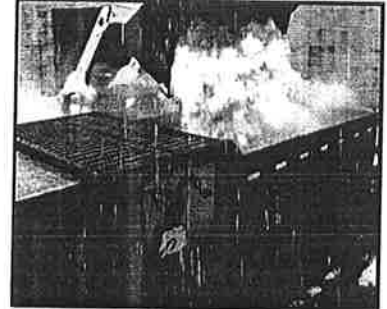

Specifications:

- 75 cubic yard rated capacity per hour
- Burner output at 9,000,000 Btu/hr
- No2 Fuel Oil or Diesel Fuel Type
- Fuel Consumption of 60 gallons/hr (max)
- Fuel Storage Capacity of 250 US Gallons
- Measures 25' long x 8'5" wide x 6'10" high

For more information on how Snow Dragon™ offers you a better tool for managing your snow removal process or to tour our 145,000 sq ft manufacturing facility located in Cleveland Ohio, call Snow Dragon Sales at 216.531.1599 or visit us online at www.SnowDragonMelters.com.

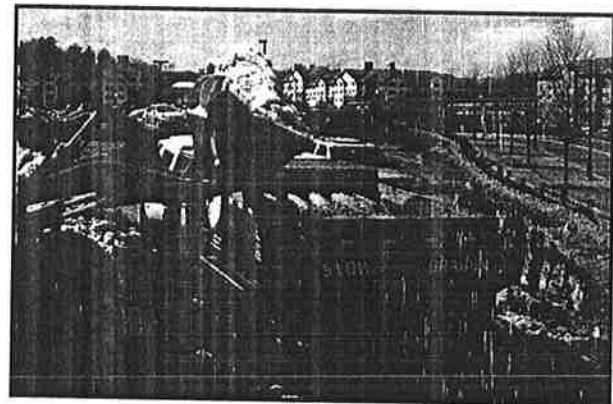
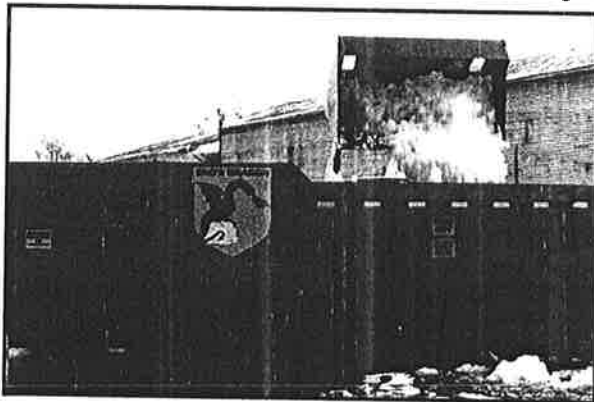

SNOW DRAGON™ SNOWMELTERS



SND1800 CONTRACTOR MODEL

The Snow Dragon™, SND1800 Model is designed for companies that handle the big commercial sites, shopping centers, stadiums, hospitals, downtown parking lots, and airports. This is also the ideal model configuration for a municipal department of streets or a state department of transportation.

SND1800 is designed to efficiently melt snow at a rate of 180 cubic yards per hour, based on a snow density of 30lbs/cf. This is equivalent to a 3 cubic yard loader bucket per minute. This system is also designed so you can pull the melter to any site as needed with your skid loader riding along on the same custom trailer or is available as a stationary unit.

The SND1800 is engineered to be a low maintenance, easy to operate system. The heated operating enclosure protects the burner, fuel tanks, generator, water pump system as well as other major components from the weather elements. The packaged burner design includes two 9,000,000 btu/hr burners that operate automatically and independent of each other. If one burner goes down during operation, the melter will continue to operate even while maintenance replaces the burner in the field.

Easy access dual side loading is another feature with the SND1800. The melting hopper tank measures a total of twenty feet long with a thirteen-foot length area for dumping snow. Other features with this model include, protective guardrails, plug and play components, quiet operation, built-in lighting system, and visual and audible alarm indication.

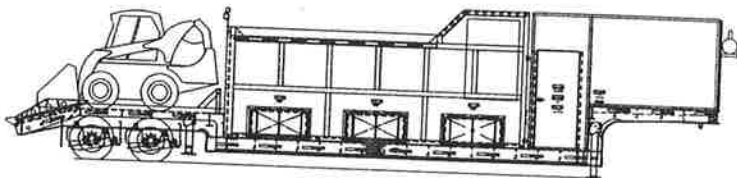
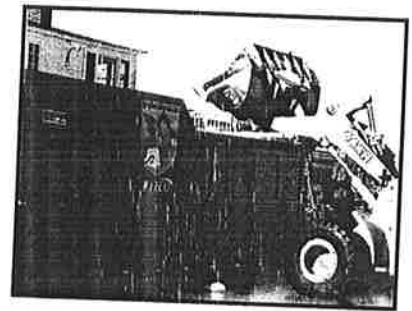
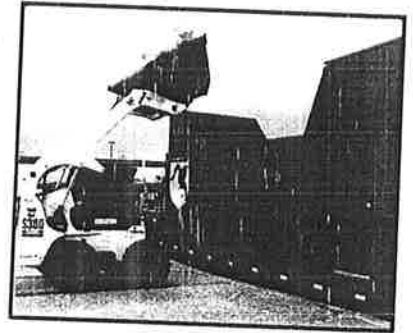

Specifications:

- 180 cubic yard rated capacity per hour
- Burner output at 18,000,000 Btu/hr
- No2 Fuel Oil or Diesel Fuel Type
- Fuel Consumption of 120 gallons/hr (max)
- Fuel Storage Capacity of 600 US Gallons
- Measures 48'10" long x 8'6" wide x 11'11" high

For more information on how Snow Dragon™ offers you a better tool for managing your snow removal process or to tour our 145,000 sq ft manufacturing facility located in Cleveland Ohio, call Snow Dragon Sales at 216.531.1599 or visit us online at www.SnowDragonMelters.com.





Snow Dragon SND1800 Spec Sheet

SPECIFICATIONS

Melt Rating	180 Cubic Yards per Hour (Based on 30lbs/cu ft snow density)
Fuel Type	No. 2 Fuel Oil or Diesel
Burner Output	18,000,000 BTU/hr
Fuel Usage	120 US Gallons per hour (max)
Fuel Capacity	600 US Gallons (standard, see options available)
Water Discharge Rate	250 Gallons per minute (max)
Water Tank Capacity	6,074 US Gallons
Weight Empty	Approx 25 tons
Weight with Fuel & Water	Approx 50 tons
Measurements	48'10" long x 8'6" wide x 11'11" high
Towing Speed	Empty 65 MPH / With Fuel 60 MPH / With Fuel & Water 50 MPH*

*Based on water level at 12"

STANDARD EQUIPMENT

1. Two (2) Automatic ignition diesel fired 9,000,000 BTU/hr packaged burners.
2. Independent burner operation allowing the melter to continue to run if one burner fails.
3. Patent Pending engineered heat exchanger tubes.
4. Standard carbon steel inner dual weir system for debris separation.
5. Standard heavy gauge mild steel melting tank with structural steel supports.
6. Dual snow loading access on both sides of melter, each with 13'-8" of clearance.
7. Heated and lighted operating enclosure with lockable access door protecting equipment including burners, control panel, water pump spray system, and generator.
8. Generator is set up to be able to be plugged into a 110 outlet when not in use to power the generator block heater and optional battery charger.
9. Two (2) emergency shut down buttons located on both sides of the melter.
10. NEMA 12 main control panel with Honeywell temperature controller, visual and audible alarm indication, Honeywell high limit controller, pilot controls, indicators, gauges, relays and terminals.
11. Self contained diesel fired 50KW generator.
12. Two (2) 200 gallons/min water recirculating stainless steel pump to mix and circulate water and to spray onto loaded snow.
13. Four (6) clean out hatches for easy cleaning, two located on each side of the melter.
14. Heavy duty flat bed trailer with air brakes, turn signals, marker lights and can accommodate a skid loader on the back end.
15. Wood rail guards positioned on the melter to prevent damage to loading sides.
16. Fifty (50) foot Fire hose included for quick water start.
17. Quiet operation.
18. Equipment designed and built to comply with National Electric Code (NEC) and National Fire Protection Association (NFPA).

OPTIONS AVAILABLE

1. Generator battery charger.
2. Stainless steel melting hopper and weir system.
3. Five (5) vibration resistant area/work floodlights.
4. Custom painting and/or decal of company logo.
5. Touch screen control panel.
6. Additional fuel storage available in place of the skid loader area.
7. Service Contract
8. As a custom engineered and manufacturing company, we can accommodate custom requests through our engineering department.

SNOW DRAGON™ SNOWMELTERS



SND5400 AVIATION MODEL

The Snow Dragon™, SND5400 Model is designed for the airport market and other large-scale users. The SND5400 is capable of melting 450 cubic yards of snow in a one-hour period based on a snow density of 30lbs/cubic feet. This Model can be supplied as a mobile unit operated off of diesel fuel, or it can be supplied as a stationary unit fueled by diesel oil or natural gas.

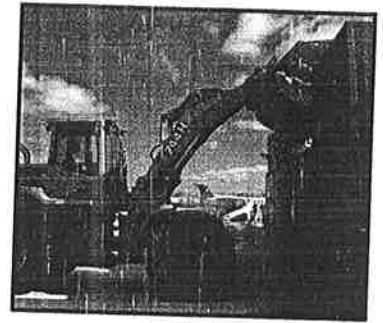

In the post 9/11 environment, the Snow Dragon™ can eliminate the security risk of trucking snow away from the airport property. SND5400 also eliminates the concern of moving environmentally contaminated snow away from the airport by keeping the snow on site and melting it there.

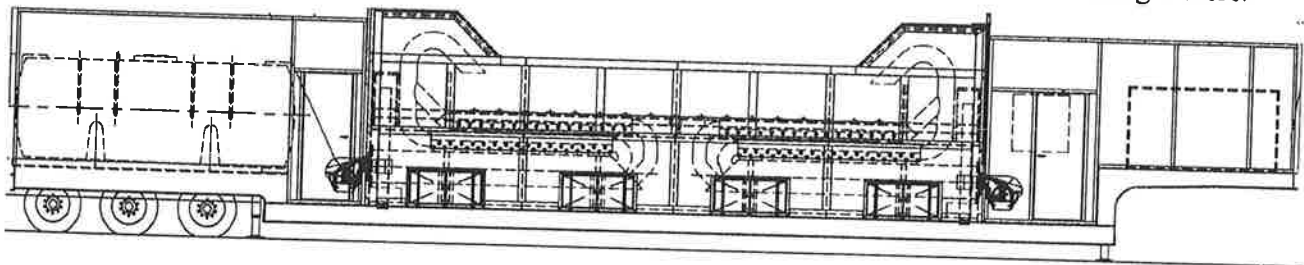

Specifications:

- 450 cubic yard rated capacity per hour
- No2 Fuel Oil or Diesel Fuel Type
- Fuel Storage Capacity of 3,000 US Gallons
- Burner output at 54,000,000 Btu/hr
- Fuel Consumption of 360 gallons/hr (max)
- Measures 68' long x 11'6" wide x 12'4" high

The SND5400 has been engineered to be an easily operated low maintenance system. The two heated operating enclosures located on each end, protect the burners, fuel tanks, generator, water pump systems as well as other major components from the weather elements. The packaged burner design includes six 9,000,000 btu/hr burners that operate automatically and independent of each other. If a burner fails during operation, the melter will continue to operate even while maintenance replaces it in the field.

Easy access dual side loading is another feature with the SND5400. The melting hopper tank measures a total of thirty-two feet long with over an eighteen foot length area for dumping snow. Other features with this model include, plug and play components, quiet operation, built-in lighting system, and visual and audible alarm indication.

Overall, the Snow Dragon™ offers you the best tool for managing your snow removal in the 21st Century. With savings between 50% to over 60%, it's no wonder why more people prefer snow melting as a part of their snow removal process. Call today or visit us online at www.SnowDragonMelters.com.

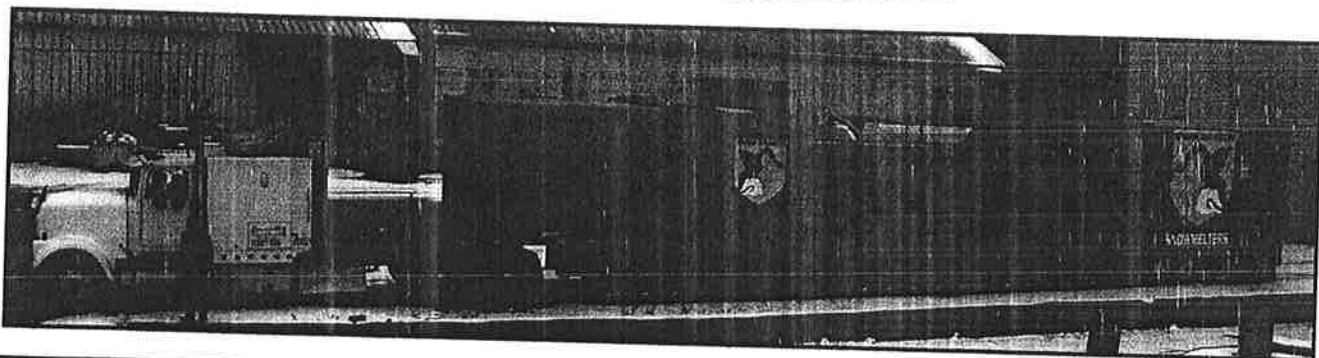



Snow Dragon

SND5400 Spec Sheet

SPECIFICATIONS

Melt Rating	450 Cubic Yards per Hour (Based on 30lbs/cu ft snow density)
Fuel Type	No. 2 Fuel Oil or Diesel
Burner Output	54,000,000 BTU/hr
Fuel Usage	360 US Gallons per hour (max)
Fuel Capacity	3,000 US Gallons
Water Discharge Rate	750 Gallons per minute (max)
Water Tank Capacity	14,500 US Gallons
Weight Empty	Approx 43 tons
Weight with Fuel & Water	Approx 100 tons
Measurements	68' long x 11'6" wide x 12'4" high
Towing Speed	Empty 55 MPH / With Fuel 50 MPH / With Fuel & Water 5 MPH*

*Based on water level at 36"

STANDARD EQUIPMENT

1. Six (6) Automatic ignition diesel fired 9,000,000 BTU/hr packaged burners.
2. Independent burner operation allowing the melter to continue to run if one or more burners fail.
3. Patent Pending designed heat exchanger tubes.
4. Standard carbon steel inner dual weir system for debris separation.
5. Standard heavy gauge mild steel melting tank with structural steel supports.
6. Dual snow loading access on both sides of melter, each with 18'-8" of clearance.
7. Two (2) heated and lighted operating enclosures protecting equipment including burners, control panel, water pump spray systems, and generator each with lockable access door.
8. Generator is set up to be able to be plugged into a 110 outlet when not in use to power the generator block heater and optional battery charger.
9. Four (4) emergency shut down buttons located on both sides of the melter.
10. NEMA 12 main control touch screen panel with Honeywell temperature controller, visual and audible alarm indication, Honeywell high limit controller, pilot controls, indicators, gauges, relays and terminals.
11. Self contained diesel fired 100KW generator.
12. Four (4) 200 gallons/min water recirculating pump to mix and circulate water and to spray onto loaded snow.
13. Eight (8) clean out hatches for easy cleaning, four located on each side of the melter.
14. Heavy duty flat bed trailer with air brakes, turn signals, and marker lights.
15. Fifty (50) foot Fire hose included for quick water start.
16. Removable filter screens for recirculating pump.
17. Quiet operation.
18. Equipment designed and built to comply with National Electric Code (NEC) and National Fire Protection Association (NFPA).

OPTIONS AVAILABLE

1. Generator battery charger.
2. Stainless steel melting hopper and weir system.
3. Ten (10) vibration resistant area/work floodlights.
4. Custom painting and/or decal of company logo.
5. As a custom engineered and manufacturing company, we can accommodate custom requests through our engineering department.

