

APPENDIX 5 -- SPECIFIC TALLY PROCEDURES

SPECIAL RULES AND EXCEPTIONS -- For most plots, the example tally sheets in Appendix 11 indicate which variables on the tally form require entries.

Alternates -- During the initial establishment of the 5 Panel Cycle, occasionally it will not be possible to establish a specified sample plot due to inadequate previous tally records. When this happens, promptly notify your supervisor. If an alternate is warranted, the plot is sent and all office and field copies of the plot listings are updated to show the change. Once an alternate is selected, the original plot is no longer in the sample and requires only a notation as to why an alternate was requested. All "replaced" plots are returned to your supervisor when the county is complete. The sample kind for an alternate plot will be 1, **5**, 6, 7 or 8. This code will not be active until the next cycle.

Census Water -- Apply one of the following rules and in the General Notes specifically identify the river, lake, or other body of water:

- If all or any portion of a remeasured plot is determined to be census water due to some change (physical or definitional) since the previous inventory, the plot is established and mapped.
- If a new plot's center (PC at subplot 1) falls on land and portions of the plot falls in census water, the plot is established and mapped.
- If a new plot's center (PC at subplot 1) falls in census water and portions of the plot falls on land, the plot is established and mapped.
- **If a new plot falls entirely in census water (i.e., all four subplots), an alternate is required.**

Reserved Land -- **Do not scribe trees on land that has been classified as reserved unless granted permission.** Lacking such permission, witness the SP, line trees, and PC with other features or landmarks.

All accessible forest land that is designated as public ownership requires the verification as to whether or not the land use is reserved (see definitions for land use 32, 33, 41 and 50). In addition all accessible forest land that is public or private requires the verification of reserve status (see variable 4.360). Field crews are not expected to contact each private landowner to verify reserve status. Crews should verify status of such private ownerships like The Nature Conservancy, National Trust for Private Lands, or other landowner groups/organizations that they suspect may have a reserve status. State supervisors may be able to provide a list of public lands and private organizations that may qualify as reserved.

It is important that verification is documented in the “General Notes” for all public ownership. Example:

- Reserved forest - Hickory Creek Wilderness Area / Source - J. Smith, ANF - KT 04/19/01
- Not reserved / Source - J. Smith, ANF - KT 04/19/01

If reserve status is verified on private ownership than only these plots require documentation in the “General Notes.” Example:

- Private reserved forest / Source - C. Jones, TNC - KT 04/19/01).

PLOT DIAGRAM RULES –

1. **A plot diagram is not required** where CONDITION CLASS STATUS 2 is the same nonforest land use for all subplots. If a plot diagram is not attached to the plot record, then a description of the nonforest condition class is required in the "General Notes." Example: All condition 1 / LU = 61 -- plot falls in cornfield.

2. **A plot diagram is required** where CONDITION CLASS STATUS 2 is comprised of multiple nonforest land uses on the subplots and the crew can occupy the plot. A "quick-rough" map and labeling of these multiple nonforest land uses on the plot diagram is required. Recording the multiple nonforest land uses as separate nonforest condition classes and associated boundaries is not required.

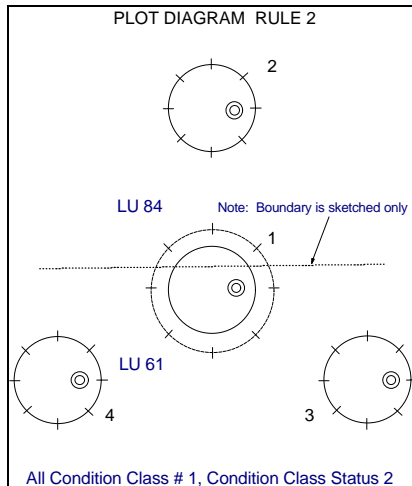

3. A plot diagram is required for plots that have a combination of CONDITION CLASS STATUS 2 through 7. Changes of condition classes, boundaries and other ground features are drawn and labeled on the plot diagram. All condition classes and associated boundaries are recorded.

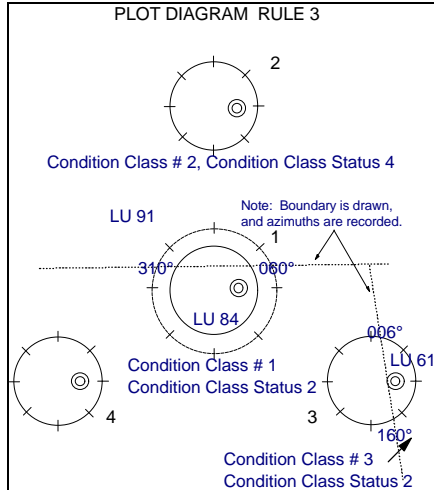

4. A plot diagram is required for all plots with CONDITION CLASS STATUS 1. Changes of condition classes, boundaries and other ground features are drawn and labeled on the plot diagram. All condition classes and associated boundaries are recorded.

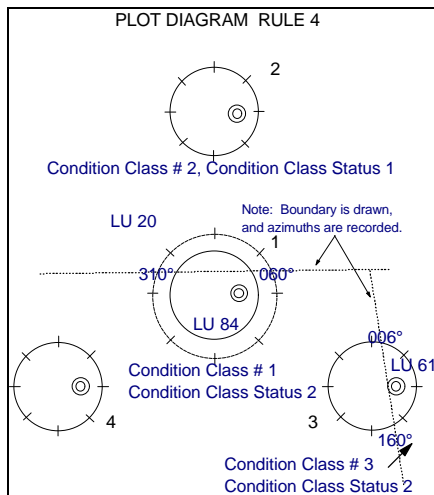

NOTE: In the situations where a plot diagram is required, the information from the diagram is helpful for remeasurement (i.e., relocating a plot) and to clarify "office" questions about the data. As with "General Notes" **the value of a good plot diagram cannot be overemphasized.**

REGULAR TALLY PROCEDURES -- All subplots on Sample Kind 1 plots, and subplots 2, 3, and 4 of Sample Kinds 6 and 7 plots are all being established for the first time during this inventory. All trees 5 inches DBH and greater within the 24.0 ft subplot radius will be tallied as part of the regular tally procedure.

RECONCILING THE PREVIOUS TALLY -- During this inventory, on remeasured plots (Sample Kind 5, 6 and 7), the trees that fall on subplot 1 are the only trees that will be reconciled to previous inventories. Only trees 5 inches DBH and greater within the 24.0 ft subplot radius will be tallied, or reconciled, as part of the regular tally procedure. All trees that are further than 24.0 ft away from subplot center will be ignored, even if they were tally trees at the last occasion.

On remeasure plots that were previously classified as nonforest, if PC at subplot 1 is still nonforest, record any forest boundaries within the 24.0 ft subplot radius. Only trees 5 inches DBH and greater on the forested conditions will be tallied. Give all trees a tree history of 22.

The following examples are common, simple situations. A correct reconciliation may be time demanding and complex. However, this is a critical part of the inventory. Training will be provided. Crews are to direct any questions to supervisors as soon as possible.

Examples:

1. The first tree to be tallied at subplot 1 is now an ingrowth, dead ingrowth, or previously missed tree. Assign the first available tree number and record the appropriate current data. If there were 35 trees on this subplot the last time, assign this tree number 036. The tree will have no data in variables 6.330 and 6.340.

The next tree tallied was tree number 001 at the last inventory. Since trees are no longer being renumbered each inventory, previous tally tree number 001 is current tree number 001. Record the appropriate current data and enter the appropriate data in variables 6.330 and 6.340.

2. The first tree on the old tally record was a 24-inch DBH sugar maple, followed by an 8-inch DBH beech. The beech is present and is the first live tree starting from an azimuth of 001. There is no evidence of the sugar maple. Check the area to the plot radius limit to see if there is a stump of the maple. Perhaps there is -- perhaps not. The maple was, and still is, tree number 001. Copy the appropriate data from the old

tally form to variables 6.330 and 6.340. Assign the proper history code in variable 6.140. The beech tree is tree number 002.

PREVIOUS TREE HISTORY CODES -- On remeasured plot, reconcile trees that have history codes that indicate they were survivors or ingrowth. In addition, trees that were assigned a tree history code of 24, 25, 31, 40, or 43 must now be assigned a new tree history code of 53 or 54, depending on whether or not they are still present. The codes that indicate these trees are highlighted below.

NOTE: The following are old history codes. They are provided here to serve as an aid in the reconciliation process. There are significant differences between these codes and the current tree history codes. These codes should never be used during the current inventory.

Also note that the tree history codes used during the previous inventory differ slightly from history codes that we currently use. If the plot has a computer generated reconciliation form, use it to reconcile the tally on the plot. The codes shown on the computer generated reconciliation form have been adjusted to align with the old tree history codes with our current codes. If a reconciliation form is not available, use the tally sheets or tally printout from the last occasion to reconcile the tally. In those situations when it becomes necessary to refer to the old tally sheets, remember that there may be some minor differences in the history codes.

**PREVIOUS TREE HISTORY CODES
FOR
ME, NH, NY, OH & PA**

Survivors -- Live, previously measured or missed trees that are currently within the boundaries of a subplot.

<u>Code</u>	<u>Definition</u>
10	same live tree -- was in before, is in now
11	multiple stemmed tree -- the product of two previously measured trees that have grown together and are now treated as one tree (used in conjunction with codes 13 and 14)
12	tree was missed at last survey -- should have been tallied but wasn't, is now tallied
13	multiple stemmed tree -- the first of two previously measured tree that grew together, treated as one now
14	multiple stemmed tree -- the second of two previously measured trees that grew together, treated as one now

19 trees that are alive, but were incorrectly tallied as dead at the last occasion – **ME & NH only**

Ingrowth -- Trees that are correctly being tallied for the first time.

20 live trees, not previously measured

21 live or dead tree, was tallied before but should not have been, is a tally tree now

22 live or dead tree, was on nonforest land, now on timberland (implies land use change)

23 live or dead tree, was on unproductive, reserved or urban forest land, now on timberland

24 dead tree or snag, too small to tally before but has grown to tally size and died since the previous inventory, is a tally tree now

25 dead tree, should have been tallied, was missed, has since died, and is now tallied

27 live or dead tree, was tallied as a sapling on the last occasion, is greater than five inches DBH now – **NY, OH & PA only**

29 live or dead tree, on sample kind 2 plot, that is located between the 49.0' (1/6 acre) and 52.7' (acre) radii – **ME & NH only**

Removals -- Previously tallied trees that:

(a) have been harvested, killed or presumed to have been harvested during a cultural operation (logging, land clearing, TSI work, etc.)

or

(b) are no longer on timberland.

30 the location where the tree is, or was, is still forested; the tree has been killed, it can be standing or down

31* the location where the tree was is still forested, the tree has been removed (usually, a stump will be present)

32 the location where the tree is, or was, is now nonforest, the tree is alive, killed, or removed (if no longer alive, it is assumed that the cause of death is not natural mortality). If the tree is no longer present, use the old DBH, distance and azimuth.

- 33** the location where the tree is, or was, is now unproductive, reserved, or urban forest land. The tree is alive, or has been killed, but is still present (if no longer alive, it is assumed that the cause of death is not natural mortality).
- 34*** the location where the tree is, or was, is now unproductive, reserved, or urban forest land -- the tree has been removed and is no longer present – **ME & NH only**

Mortality -- Previously tallied trees that have died since the last inventory.

- 40** dead tree -- standing or down -- tree is still present; when DBH measurement is not possible, or current DBH is smaller than the previous DBH, use previous DBH for current
- 41*** dead, down, disintegrated, no evidence remaining; previously measured trees that have died and are in advanced stages of decay, or any previously measured tree that cannot be accounted for
- 42** dead tree, standing or down, now located on nonforest land
- 43** dead tree, standing or down, now located on unproductive, reserved, or urban forest land
- 44*** dead, down, disintegrated, no evidence remaining; the land where it was is unproductive, reserved, or urban forest – **ME & NH only**

Other Trees

- 50*** tree that was tallied before, but should not have been (was out), is still out this time, not tallied now
- 51*** dead tree or snag at the previous occasion, is a snag now; tree was not a tally tree at the last occasion because dead trees and snags were not tallied then, tree definitely was not “missed” at the last occasion (check code 25). – **NY, OH & PA only**
- 53*** trees with a previous tree history of 22, 31, 40, that are still present (standing or down) – **ME & NH only**
- 54*** trees with a previous tree history of 22, 31, 40, that are no longer present (no evidence of the tree remains) – **ME & NH only**

- 55* trees that were tallied as being within the 49.0 ft. plot radius last time, and are now accurately measured as being beyond 49.0 ft. this time.
– **ME & NH only**
- 58* trees that were poletimber at the last occasion, were greater than 24.0 ft away from plot center, and are still poletimber beyond 24.0 ft.
– **NH only**
- 59* trees that were sawtimber at the last occasion, were greater than 49.0 ft away from plot center, and are still beyond 49.0 ft. – **NH only**
- 70 trees that were properly tallied at the last occasion but were not included on the electronic history files due to a keypunching error. – **ME & NH only**

* Trees with these previous history codes are not reconciled.

PREVIOUS TREES THAT ARE NOT ON THE HISTORY FILE --Occasionally the history files used in the data recorder program are incorrect. These errors must be detected and corrected. To do so, all remeasured plots must be reconciled to the printed or handwritten tally records from the last occasion. The history files that are transferred to the data recorder cannot be relied upon to be complete. A check of the current tally against the previous tally must be completed for each plot.

If a tree that was tallied correctly at the last occasion but is not contained in the plot history file is discovered, enter the previous tree number that is on the plot print out and assign the appropriate tree history. You will also need to enter the previous diameter and previous tree class / merchantability class. This information is also on the plot print out.

SPECIAL INSTRUCTIONS FOR THE OHIO INVENTORY -- During the last periodic Ohio inventory the majority of the plots established were a 10-point design. 37.5 BAF prisms were used to sample the trees on each of the ten points. For the new inventory, the national 4-subplot design will overlay this 10-point design. **In order to establish a growth, removal and mortality estimates, a partial remeasurement on five of the ten points will be completed during the first 5-year cycle of the Annual Forest Inventory.** The previous “prism” points to be reconciled are 1, 2, 6, 7 and 8. (See Figure 1)

Figure 1: 10-point with 4-subplot overlay

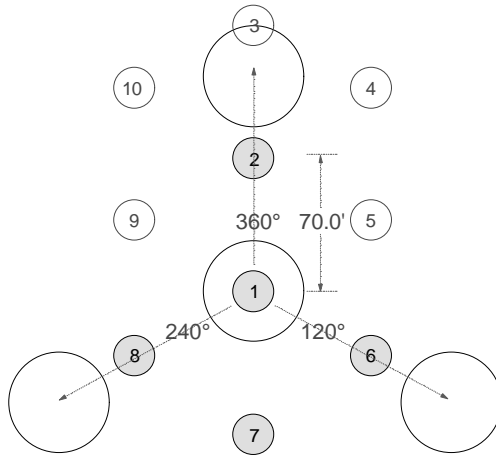

On the tally sheet and data recorder “prism” points 1, 2, 6, 7 and 8 will be renumbered as 5, 6, 7, 8 and 9. The national 24 ft fixed radius subplots will continue to be numbered 1 through 4. (See Figure 2)

Figure 2: New numbers for prism points

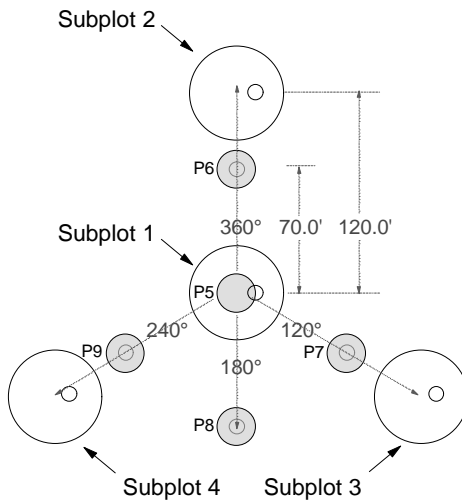

The following tree variables will be collected on the “prism” points:

- TREE RECORD NUMBER
- SPECIES
- TREE HISTORY
- DBH
- TREE CONDITION CLASS
- TREE CLASS
- MERCHANTABILITY CLASS
- PREVIOUS DBH
- PREVIOUS TREE CLASS / MERCHANTABILITY CLASS
- **NOTES**

In addition, ingrowth (trees 5-in and greater at DBH) will be measured on a microplot (6.8 ft radius) located at point center (PC). **Even though point 5 is concentric with subplot 1, it will be necessary to complete a separate tally for these ingrowth trees.** The tree variables on the “ingrowth” microplots will be the same as the “prism” points. (See Appendix 11, Ohio Tally Guide).

NOTE: Even though you are not recording tree grade, lengths and culls, these variables need consideration prior to assigning tree class and merchantability class.

Crews will be supplied with a printout of the previous tally trees to be reconciled from these points. Since these were prism tallies, it is important to realize that **“prism” trees may be located 70 ft or more from PC depending on the DBH and percent slope.** E.g., A tree with a 40-in DBH, no slope, has a limiting “horizontal” distance of 56.8 ft.; same tree, 60% slope, has a limiting “slope” distance of 66.2 ft. Since the tally was dependent on the limiting distance, large diameter trees could occur on multiple points. **To reconcile “prism” points, the horizontal distance is measured from PC to the center of the tree at DBH.**

On the last occasion crews tallied the points in order from one to ten. Each point was located 70 ft and 360°, 120°, 240°, or 300° from the last point. In addition all ten points were located in the same condition. The condition was defined at plot center of point 1. Points that fell in contrasting conditions were rotated from the highest non-rotated point.

For example, point 1 through 10 fell in forest land except for point 7 (P8). The first location to establish this rotated point would be 70 ft at 360° from point 10, then at 240°, and finally at 300°. (If point 10 did not yield a location, then the same procedure was followed at point 9 at 240°, etc. This procedure was continued until the point could be established in the same condition as point 1.) The point was then renumbered as point 17 (P8) to indicate the rotation, and the new point location was documented on the plot diagram. (See Figure 3)

Figure 3: "Old" point rotation procedure

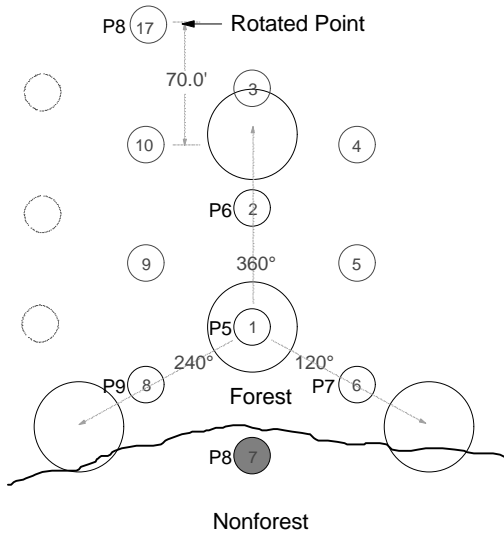

On this occasion complete the “regular” tally at subplot 1, and then complete the “partial” tally of point 5. The previous trees from “prism” point 5 within the 24 ft radius of PC at subplot 1 will require a second tally to complete the reconciliation. It is important that all “like” tree variables match between subplot 1 and point 5. The remainder of the subplots and “prism” points should be completed as field conditions warrant. I.e., A crew may find it more efficient to complete subplot 2 before completing “prism” point 6 or vice versa.

SPECIAL INSTRUCTION FOR THE NEW YORK INVENTORY -- During the last periodic New York inventory the majority of the plots established were a 10-point design. After the 10-point reconciliation was completed, a 1/5-acre overlay was completed at point 1. (See Figure 4).

Figure 4: 10-point with 1/5 acre overlay

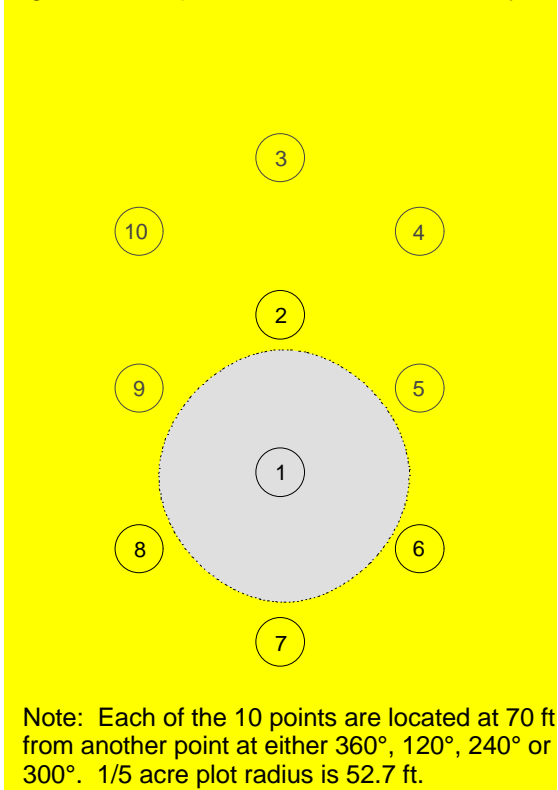

On the last occasion only minimal tree data was collected on the overlay. These variables were the following:

- TREE RECORD NUMBER
- SPECIES
- HORIZONTAL DISTANCE
- AZIMUTH
- DBH
- TREE CONDITION CLASS
- TREE CLASS
- MERCHANTABILITY CLASS
- NOTES

On this occasion only the trees from the 1/5-acre overlay are reconciled at subplot 1. Crews will be supplied with a history data of the previous tally trees to be reconciled from the 1/5-acre overlay within subplot 1. All plot variables are collected. Additional tally from the old 10-point design will be ignored. However, this information will be attached to the plot record and may aid you in relocating the plot. (See Figure 5)

Figure 5: 10-point with 1/5 acre and new 4-subplot overlay

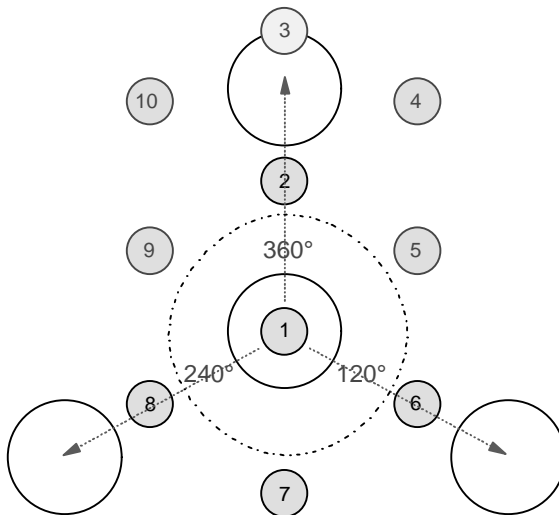

OTHER PREVIOUS PLOT DESIGNS – Additional figures 6 through 8 are to aid in relocating remeasure plots.

Figure 6: Old OH & PA 1/5 acre with new 4-subplot overlay

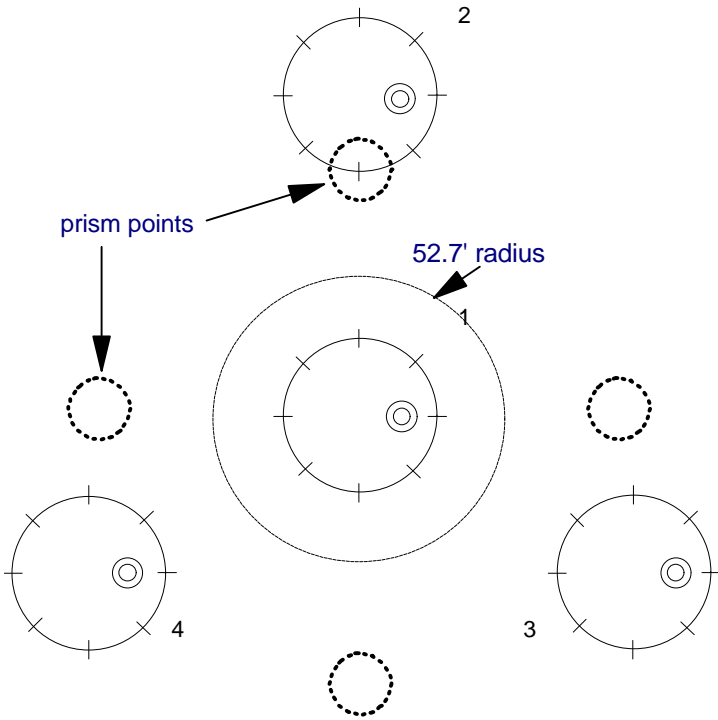

Note: Plots established in OH & PA on the previous occasion, consisted of a 1/5th acre with variable radius points located 98.4 ft at 360°, 90°, 180° and 270° from point 1.

Figure 7: Old NH Plot Design

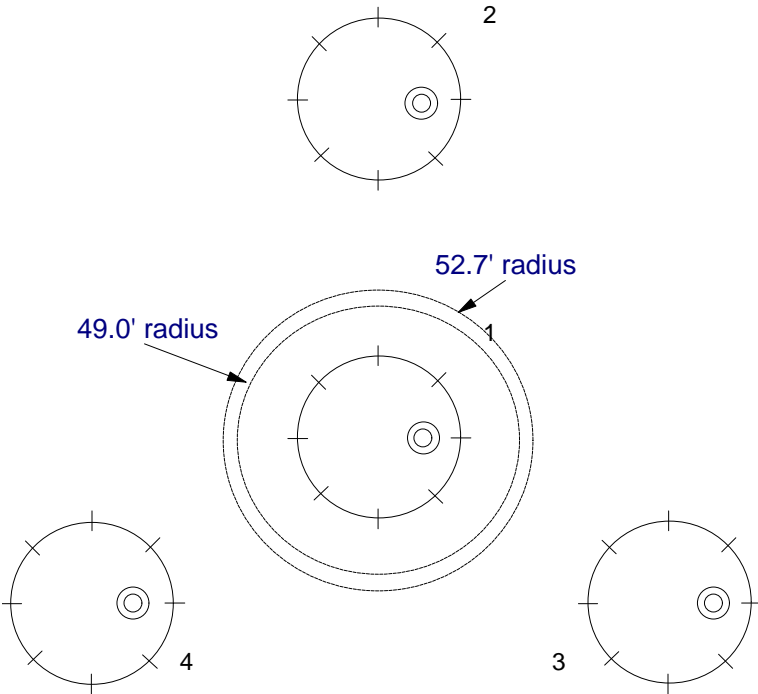

Note: Plots established in NH on the previous occasion, consisted of the current 4-subplot design overlaid on either an older 1/5th acre or 1/6th acre plot.

Figure 8: Old ME or NY 1/5th or 1/6th acre plot with new 4-subplot overlay

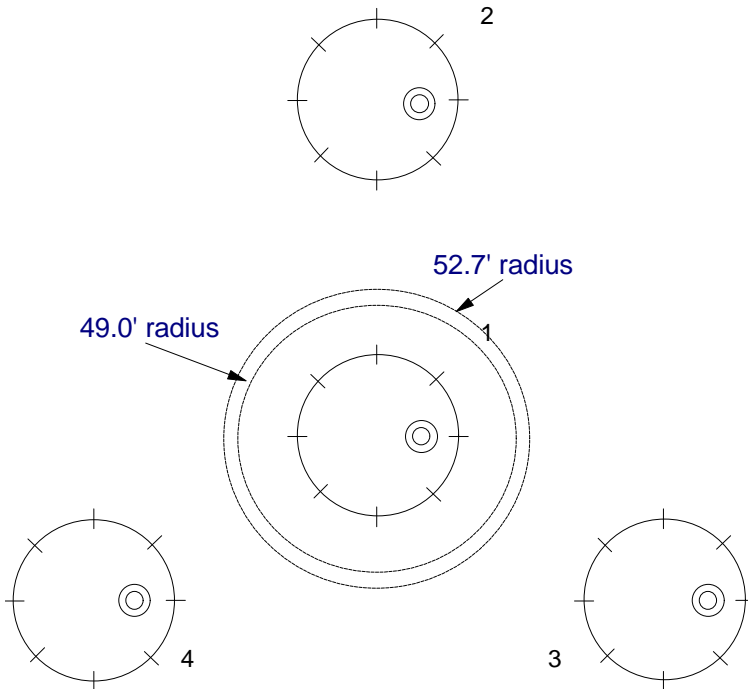

Note: Plots established in ME & NY on the previous occasion, consisted of either a 1/5th or 1/6th acre plot.